

EQUIPMENT:
PUBLICATION:
ISSUE No. & DATE:

T1200-C
MARINEC-P-I
1 11/12

TYCO T1200-C
Marine Fire Detection/Alarm Control Panel and Repeater
Installation and Commissioning Manual

List of Contents

1. LIST OF FIGURES	3	7.9.8 <i>REPEATERS</i>	24
2. LIST OF TABLES	3	7.9.9 <i>REPEATER MUSTER LINK [IF FITTED]</i>	24
3. INTRODUCTION	4	7.9.10 <i>POWER SUPPLY UNIT</i>	24
4. INSTALLATION AND COMMISSIONING OVERVIEW	4	7.9.11 <i>FINAL DRESSING OF THE CABLES</i>	25
5. INSTALLATION	4	8. USER INDICATIONS	26
5.1 <i>ELECTRICAL SAFETY</i>	4	9. USER CONTROLS	27
5.2 <i>INSTALLATION INSTRUCTIONS</i>	6	10. PCB LAYOUTS	28
5.2.1 <i>T1200-C PANEL INSTALLATION</i> <i>INSTRUCTIONS</i>	6	11. INSTALLATION DETAILS	33
5.2.2 <i>CONNECTION OF THE INCOMING POWER</i> <i>SUPPLY (AC & DC)</i>	8	12. WIRING DIAGRAMS	37
5.2.3 <i>BATTERY BOX INSTALLATION</i>	8	13. CONSTRUCTION PRODUCTS DIRECTIVE	43
5.2.4 <i>BATTERY INSTALLATION</i>	9		
5.2.5 <i>BATTERY CONNECTION</i>	9		
5.2.5.1 <i>CONNECTING THE BATTERY BOX TO THE</i> <i>PANEL PSU9</i>			
5.2.6 <i>INSTALLATION AND CONNECTION OF THE</i> <i>C1631 REPEATER INTERFACE</i>	10		
5.2.7 <i>INSTALLATION AND CONNECTION OF THE</i> <i>C1665 MUSTER INTERFACE</i>	12		
5.3 <i>REPLACING THE DISPLAY INSERTS</i>	13		
5.3.1 <i>TO CHANGE THE INSERTS</i>	13		
5.3.2 <i>TO FIT THE OPTIONAL DOOR STAY</i>	14		
6. COMMISSIONING	15		
6.1 <i>INTRODUCTION</i>	15		
6.2 <i>COMMISSIONING CHECKLIST</i>	15		
6.3 <i>AN OVERVIEW OF THE COMMISSIONING</i> <i>PROCEDURE</i>	15		
6.4 <i>PRE-COMMISSIONING WIRING CHECK</i>	16		
6.5 <i>POWERING UP</i>	17		
6.6 <i>CONFIGURATION</i>	17		
6.6.1 <i>BASIC DEFAULT CONFIGURATION</i>	17		
6.6.2 <i>VESSEL-SPECIFIC CONFIGURATION</i>	17		
7. OPERATING THE ENGINEER'S FUNCTIONS	17		
7.1 <i>ENGINEER'S ZONE/OUTPUT CONFIGURATION</i> <i>PROCESS</i> :.....	17		
7.2 <i>ZONE OR OUTPUT CONFIGURATION</i>	18		
7.3 <i>TO RESTORE THE FACTORY DEFAULT</i> <i>CONFIGURATION FOR ZONES & OUTPUTS</i> :	19		
7.4 <i>ENGINEER'S ZONE/OUTPUT CONFIGURATION</i> <i>TIME-OUT WARNING</i> :	19		
7.5 <i>INVALID CONFIGURATION CONDITIONS</i> :	19		
7.6 <i>LIST OF CONFIGURATION DIL SWITCHES AND</i> <i>THEIR FUNCTIONS</i>	19		
7.7 <i>LIST OF LINK CONFIGURATION FEATURES</i>	21		
7.8 <i>DIL SWITCH SETTINGS ON THE REPEATER</i> <i>INTERFACE BOARD</i> :	22		
7.8.1 <i>C1630 OUTPUT INTERFACE</i> <i>CONFIGURATION</i>	22		
7.9 <i>COMMISSIONING PROCEDURE</i>	23		
7.9.1 <i>ALARM CIRCUITS</i>	23		
7.9.2 <i>DETECTION ZONES</i>	23		
7.9.3 <i>CLASS CHANGE INPUT</i>	23		
7.9.4 <i>FIRE AND FAULT OUTPUTS</i>	23		
7.9.5 <i>FIRE PROTECTION OUTPUT</i>	23		
7.9.6 <i>ANCILLARY INPUTS</i>	24		
7.9.7 <i>ANCILLARY OUTPUTS</i>	24		

1. List of Figures

FIGURE 1 – BULK HEAD MOUNTING DETAILS	8
FIGURE 2 – BATTERY CLAMP DETAILS - T1200B	10
FIGURE 3 – BATTERY CLAMP DETAILS - T1200B-C ...	11
FIGURE 4 – REPEATER CONNECTION DIAGRAM	12
FIGURE 5 – MUSTER INTERFACE WIRING DIAGRAM ...	12
FIGURE 6 – DISPLAY INSERT REPLACEMENT	14
FIGURE 7 – DOOR STAY ASSEMBLY	15
FIGURE 8 – C1626 PCB LAYOUT	28
FIGURE 9 – C1627 MOTHERBOARD LAYOUT	29
FIGURE 10 – C1632 16 ZONE EXPANSION BOARD LAYOUT	30
FIGURE 11 – REAR RIGHT HAND SIDE OF DISPLAY PCB	30
FIGURE 12 – C1714 VDR OUTPUT MODULE PCB LAYOUT	31
FIGURE 13 – C1630 OUTPUT EXPANSION INTERFACE	32
FIGURE 14 – C1631 REPEATER INTERFACE BOARD .	32
FIGURE 15 – C1665 MUSTER INTERFACE BOARD.....	32
FIGURE 16 – T1204 INSTALLATION DRAWING.....	33
FIGURE 17 – T1200B-C ENCLOSURE DETAILS.....	34
FIGURE 18 – T1216-C INSTALLATION DRAWING	35
FIGURE 19 – T1232-C INSTALLATION DRAWING	36
FIGURE 20 – MAINS AC CHANGE-OVER UNIT ELECTRICAL INSTALLATION DIAGRAM	37
FIGURE 21 – T1216-C ELECTRICAL INSTALLATION DIAGRAM.....	38
FIGURE 22 – T1232-C ELECTRICAL INSTALLATION DIAGRAM.....	39
FIGURE 23 – T1204DC ELECTRICAL INSTALLATION DIAGRAM.....	40
FIGURE 24 – T1204A1/A2 ELECTRICAL INSTALLATION DIAGRAM.....	41
FIGURE 25 – T1216R-C/T1232R-C REPEATER ELECTRICAL INSTALLATION DIAGRAM	42

2. List of Tables

TABLE 1 – CONTENTS OF SPARES BAG.....	6
TABLE 2 – C1631 SETTING FOR QUANTITY OF REPEATERS	22
TABLE 3 – C1631 SETTING FOR REPEATER ADDRESSES	22
TABLE 4 – SETTING QUANTITY AND TYPE OF O/P MODULES ON THE C1630	22
TABLE 5 – SETTING C1714 VDR PANEL NUMBER.....	22

T1200-C

MARINEC-P-I

1 11/12

3. Introduction

This document contains all the information necessary for the installation, commissioning and maintenance of the T1200-C range of panels and repeaters.

NOTE: Read this manual fully before commencing installation.

The following supporting documentation is also available:

- T1200-C Sales Literature
- T1200-C Panel Application Guide
- T1200-C User Manual
- T1200-C Log Book
- T1200-C Insert Template
- Mains AC Changeover Unit Fixing Instructions.

Note: References are made throughout this document to “Fire Protection Output” and Fire Output”. These refer to particular outputs from the T1200-C panels and are provided for specific purposes:

- **Fire Protection Output:** An output used to activate ancillary fire protection equipment or systems. For example, fire doors or plant shutdown.
- **Fire Output:** An output used to send a common fire warning signal to a remote fire monitoring station.

References are also made to “Manual Fire Alarm” and “Muster”. These relate to fire alarm sounder operating modes which are activated manually from the fire panel display. The panel is configurable to one or other of the two modes.

Detailed descriptions of both modes are provided within this manual.

4. Installation and Commissioning Overview

This section lists the steps that are taken in installing and commissioning a T1200-C system. Refer to the T1200-C Application Guide for technical details and description of panel features.

1. Install all field wiring and equipment.
Refer to the Installation instructions in section 5. Refer to the relevant field device installation manuals.
2. Install the panel.
Refer to the installation instructions in section 5. Do not connect the field equipment at this stage.
3. Connect any repeaters (if applicable).
Refer to the installation instructions in section 5.2.
4. Commission the panel.
Refer to section 6.

5. Installation

The control panel must be installed by suitably qualified technicians familiar with the installation of fire detection & alarm systems. In addition, it is recommended to refer to the following information:

- The current edition of the relevant wiring regulations for ships.
- Any specific vessel requirements.
- Any field device installation instructions.
- Any data sheet provided for the installation of Intrinsically Safe devices.

Notes:

The rating plate, containing essential electrical information is located on the outside of the panel, on the left side.

The mains supply cable should be a minimum of 1mm² copper protected by a 5A fuse.

An appropriate lockable double pole disconnect device must be provided as part of the vessel installation. This device must have a minimum contact gap of 3mm.

If the Mains AC Changeover Unit is being used then both AC feeds into the unit should have a double pole disconnect device, with suitable instructions on how to disconnect the AC mains power.

5.1 Electrical Safety



WARNING:

Prior to commencing installation of the control panel, ensure that adequate precautions are taken to prevent damage to the sensitive electronic components on the display board and the control board due to electrostatic discharge. You should discharge any static electricity you may have accumulated by touching a convenient earthed object. You should repeat the process at regular intervals during the installation process, especially if you are required to walk over carpets.

If possible, wear an anti-static wrist strap connected to a suitable earth point when working on the panel.

The panel must be located in an area which complies with the environmental specification detailed in the T1200-C Application Manual and should be at least 2 metres away from pager systems or any other radio transmitting equipment. The operating temperature range of the panel & repeater is -10°C to +55°C. Batteries are housed in a separate enclosure and are rated as operational between -20°C to +50°C for charging purposes. Maximum humidity is 95% for panel, repeater & batteries.

IMPORTANT NOTES ON BATTERIES:



DANGER: Batteries are electrically live at all times, take great care never to short circuit the battery terminals.



WARNING: Batteries are often heavy; take great care when lifting and transporting batteries. For weights above 24 kilos, lifting aids should be used.



DANGER: Do NOT attempt to remove the battery lid or tamper with the internal workings of the battery. Electrolyte is a highly corrosive substance, and presents significant danger to yourself and to anything else it touches. In case of accidental skin or eye contact, flush the affected area with plenty of clean, fresh water and seek immediate medical attention.

Valve Regulated Lead Acid (VRLA) batteries are “low maintenance”, requiring no electrolyte top-up or measurement of specific gravity.

WARNING: Only clean the battery case with a cloth that has been soaked or dampened with distilled water. Do not use organic solvents (such as petrol, paint thinner, benzene or mineral spirits) or other materials that can substantially weaken the case. Do not use a dry cloth as this will generate static electricity, which in turn may lead to an explosion.

WARNING: Avoid operating temperatures outside the range of -15°C/5°F to +50°C/122°F for float/standby applications.

The recommended normal operating temperature is 20°C.

HIGH TEMPERATURE will reduce battery service life. In extreme cases this can cause Thermal Runaway, resulting in high oxygen/hydrogen gas production and battery swelling. Batteries are irrecoverable from this condition and should be replaced.

LOW TEMPERATURE will prolong battery life but reduce output capacity.



DANGER
Harmful fumes

DANGER: Do not incinerate batteries. If placed in a fire, the batteries may rupture, with the potential to release hazardous gases and electrolyte. VRLA batteries contain substances harmful to the environment.



Exhausted batteries must be recycled. Return them to the battery manufacturer or take them to your Council waste disposal site for appropriate disposal.

ELECTRICAL SAFETY:

The volt-free relay contacts provided within the panel must not be used to directly switch any voltage that exceeds 30V. (Please also refer to relay rating data).

A 9V battery is supplied fitted to the inside of the door. This battery provides power to the buzzer in the event of total power failure or display ribbon disconnection. The connecting lead of this battery is disconnected from the display board during shipping.

1. DO NOT short circuit the battery terminals or the connecting lead.
2. DO NOT remove this battery unless it measures 8V or less.
3. DISCONNECT THE LEAD from the display board BEFORE replacing the battery to avoid accidental polarity reversal which may damage the display circuitry.
4. ALWAYS secure the battery in the battery holder with a Tie-wrap.
5. DO NOT use rechargeable batteries as these will gradually discharge due to internal resistance.

Some of the panels covered by this manual require a 110Vac or 230Vac supply. Refer to the equipment rating plate and T1200-C Application Manual for detailed information.

All installation work should be carried out in accordance with the recommendations of the current edition of the IEE regulations by suitably qualified and trained personnel.



This is an IEC Class 1 electrical appliance and therefore must have the chassis connected to an electrical earth.

T1200-C

MARINEC-P-I

1 11/12

5.2 Installation Instructions

1. Carefully remove the control panel from the packing and lay the panel on a suitable flat surface.
2. Locate the spares bag (either inside the packing box or inside the panel) and check all items are present as shown in Table 1.

Table 1 – Contents of Spares Bag

ITEM	T1204 A1/A2	T1204DC	T1216-C	T1232-C	T1216R-C	T1232R-C	T1200B-C
Mains fuse	T3.15AH 250V 20mm	T5AH250V 20mm	T5AH250V 20mm	T5AH250V 20mm			
Battery fuse	T2AH250V 20mm	T8AH250V 20mm	T8AH250V 20mm	T8AH250V 20mm			
End-Of-Line resistors for zone circuits	4 off 10k 0.25W	4 off 10k 0.25W	16 off 10k 0.25W	32 off 10k 0.25W			
End-Of-Line resistors for alarm circuits & monitored outputs	7 off 3k9 0.25W	7 off 3k9 0.25W	7 off 3k9 0.25W	7 off 3k9 0.25W			
Access Controls Key Ref - 801	2	2	2	2	2	2	
Red battery Lead	250mm	250mm	250mm	250mm			
Black Battery Lead	250mm	250mm	300mm	300mm			
Blue Battery Lead	640mm	640mm	250mm	250mm			
Cable Tie	2	2	1	1			
Neoprene washers for bulkhead mounting.	6	6	8	8	8	8	6
Alternative Button insert	Panel English	Panel English	Panel English	Panel English	Repeater English	Repeater English	
TYCO Logo Label	1	1	1	1	1	1	
THORN Logo Label	1	1	1	1	1	1	
T1200C Documentation CDROM	1	1	1	1	1	1	
C1631 Interface Board					1	1	

5.2.1 T1200-C Panel Installation Instructions

Note: The panel is supplied configured for bottom cable entry (except for the T1204). If top cable entry is required then the door of the enclosure should be removed & fitted to the opposite side of the enclosure. The installation instructions below apply to top or bottom cable entry.

1. Ensure that the panel is on a flat surface with the door facing up.
2. Remove the panel door as follows:
 3. Undo the two slotted bolts that secure the door shut. The bolts will remain attached to the door.
 4. Open the door. Note that the door will open past 180 degrees and will put tension on the hinges if no support is provided underneath. You may find it useful to place the packing box underneath the door to provide support.
 5. Locate the ribbon cable connecting the display board to the main control board (motherboard). Push the metal retaining clip off the connector

on the display board and pull the ribbon cable out of the connector.

6. Locate the earth strap connected to the door. Pull the earth strap connector off the spade terminal on the door.
7. Use a suitable flat blade screwdriver to unscrew the hinges whilst supporting the door.
8. Place the door and hinge fixing screws carefully to one side.
9. The chassis is fixed to the enclosure backbox at five points. Three of these points are key-hole type; two are round holes for screws.
10. Remove the Chassis from the enclosure as follows:

On the T1204:

- (a) Disconnect the earth lead from the spade terminal on the chassis near the mains terminal block.
- (b) Remove the two cross-head screws at the bottom left & right corners of the chassis.
- (c) Loosen the two cross-head screws at the top left & right corners of the chassis but do not remove them.
- (d) Slide the chassis so that the loosened bolts are free of the key-hole slots.
- (e) Lift the chassis out of the enclosure and place carefully to one side.
- (f) Observe that there is a key-hole fixing in the centre of the chassis which slides onto a post. Care should be taken when replacing the chassis that this key-hole slides onto the post correctly.

On the T1216-C & T1232-C:

- (a) Disconnect the chassis earth lead from the spade terminal on the enclosure backbox.
- (b) Remove the two cross-head screws at the bottom left & right corners of the chassis (towards the gland plate).
- (c) The three key-hole fixings do not have screws.
- (d) Slide the chassis free of the key-hole slots.
- (e) Lift the chassis out of the enclosure and place carefully to one side. Note that the chassis is heavy and caution should be taken when lifting the chassis.
- (f) Observe that there is a key-hole fixing in the centre of the chassis which slides onto a post. Care should be taken when replacing the chassis that this key-hole slides onto the post correctly.

NOTE: The door and chassis both contain Control Boards with sensitive and fragile electronic components on them. You must place these items in a location where they will not be

damaged. Use the packing box to place these items inside, ensuring that the door & chassis remain separated. Store them in a safe place which is clean, dry and dust-free.

Note: Do not allow the door & chassis to come into contact with the packing foam as this may hold a static charge.

11. Locate the earth lead connecting the gland plate to the earth bar. Disconnect the earth lead from the earth bar.
12. Remove the screws securing the gland plate to the enclosure. Remove the gland plate.
13. Use a centre punch and hammer to remove the required knock-outs by placing the centre punch diagonally opposite the fixing point on the knockout and striking the centre punch with the hammer. **DO NOT** remove the knock-outs from any unused cable entries.
14. The T1204 has an additional gland plate without knockouts. You will need to drill the appropriate holes if you want to use this gland plate.
15. Refit the gland plate ensuring that the seal is correctly seated.
16. Re-connect the earth lead from the gland plate to the earth bar.

For Bulk Head mounting:

- (a) Identify the indented holes in the back of the enclosure that are used to mount the enclosure. The T1204 has three holes, the T1216-C & T1232-C have four holes.
- (b) Mark the location of one of the upper fixing holes on the wall/bulkhead. Drill and fix with a suitably plated or stainless steel M5 nut, bolt and washers (fixings not supplied). The fixing must be sealed using two neoprene washers [supplied with the panel fixing kit], one fitted between the panel and the bulkhead and the other fitted between the panel and the steel washer inside the panel. See Figure 1 – Bulk Head Mounting Details. Do not fully tighten at this stage.
- (c) Level the panel and fix the remaining fixing points as above.
- (d) Check that neoprene seals have been fitted as shown in Figure 1 then fully tighten all of the fixing nuts & bolts.
- (e) Check that the enclosure is firmly seated against the bulk head and is not deformed in any way.

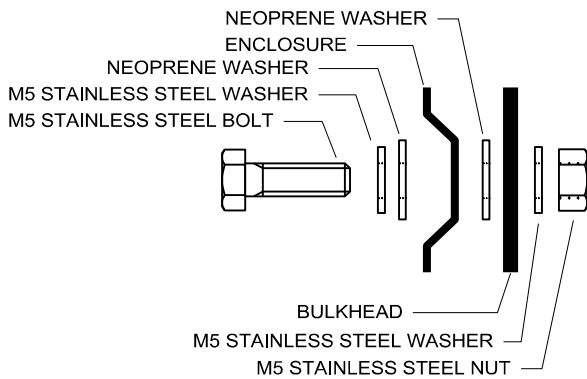



Figure 1 – Bulk Head Mounting Details

For Console mounting:

Note: The T1204 cannot be mounted in a console.

- (a) Cut a suitable hole in the console to fit the enclosure. Dimensions are shown in section 11.
 - (b) Identify the four holes in the outer flange of the enclosure that are used to mount the enclosure in a console.
 - (c) Insert the enclosure into the console. Note that the flange will not sit flush with the console at this stage because of the four bushes used for securing the door.
 - (d) Mark the centre positions of the four bushes. Remove the enclosure and drill suitable sized holes to accommodate the bushes (13mm to 15mm diameter).
 - (e) Insert the enclosure into the console and check that the flange now sits flush with the console. Drill suitable mounting holes in the console & fix with M5 counter-sunk screws.
17. Bring all field wiring into the enclosure through cable glands, ensuring that the cable conductors are of sufficient length inside the enclosure (at least 30cm). Waterproof glands and seals should be used to maintain ingress protection against water. Ensure that all conductors are clearly labelled. Any unused cable entries which are open must have waterproof knockout seals fitted.
 18. Connect the earth drain wires of the field cabling to the earth bar(s) positioned at the back of the back-box. Up to two drain wires may be connected to each terminal.
 19. Ensure that the electrical continuity of any cable shield is maintained through to the last device on the circuit. The shield must only be connected to enclosure earth in the panel by using the earth bars provided.
 20. Clear any dust and debris from inside the enclosure.

21. Reinstallation of the chassis is the reverse of removal. Ensure that all keyholes on the chassis are fully mounted onto the posts in the back-box.
22. Reconnect all earth wires and ensure none are trapped between the chassis and back-box. Do not connect the field wiring at this stage.
23. Refit the door. The refitting procedure is the reverse of removal. Ensure that the earth strap and ribbon cable are reconnected correctly.
24. If a door stay is supplied then this should now be fitted following the instructions in section 5.3.2.
25. Connect the incoming protective earth conductor to the Earth terminal in the mains terminal block. This is the primary earth point and is labelled  [Also labelled E]; see section 12. Wiring Diagrams.
26. **NOTE:** When shutting the door of the panel, DO NOT over tighten the thumb-screws. Tighten until finger-tight and then turn another quarter-turn using a screwdriver.

5.2.2 Connection of the incoming Power Supply (AC & DC)

Note: For installations requiring the Mains AC switch-over unit, a 24Vdc supply will need to be connected from the panel to the AC mains switch-over unit to drive the LED indications. See Figure 20 for wiring details.

1. With both poles of the incoming power supply safely isolated at the feeder end, connect the Live [AC] conductor to the mains terminal block [L terminal] or positive [DC] conductor to the +VE terminal as indicated in section 12. Wiring Diagrams.
2. Connect the Neutral [AC] conductor to the mains terminal block [N terminal] or negative [DC] conductor to the -VE terminal as indicated in section 12. Wiring Diagrams.
3. Secure the incoming supply cable using the cable tie supplied. **NOTE:** The cable tie should be over the outer cable insulation.

5.2.3 Battery Box Installation

There are two types of battery box; the T1200B is for use with the T1204 panels, the T1200B-C is for use with the T1216-C, T1232-C and T1216W-C panels.

The battery boxes can only be bulk-head mounted. The incoming cable must have an in-line fuse in the positive power supply (fuse type: T6.3A HRC). The fuse must be mounted external to the battery box, in a suitable terminal box which is close-coupled to the battery box. See Figure 21, Figure 22, Figure 23 and Figure 24 for wiring details.

Follow the instructions below to mount the battery box:

- (a) Identify the three indented holes in the back of the enclosure that are used to mount the enclosure.
- (b) Mark the location of one of the upper fixing holes on the wall/bulkhead. Drill and fix with a suitably plated or stainless steel M5 nut, bolt and washers (fixings not supplied). The fixing must be sealed using two neoprene washers [supplied with the fixing kit], one fitted between the panel and the bulkhead and the other fitted between the panel and the steel washer inside the panel. See Figure 1 – Bulk Head Mounting Details. Do not fully tighten at this stage.
- (c) Level the enclosure and fix the remaining fixing points as above.
- (d) Check that neoprene seals have been fitted as shown in Figure 1 then fully tighten all of the fixing nuts & bolts.
- (e) Check that the enclosure is firmly seated against the bulk head and is not deformed in any way.
- (f) Mount the fused terminal box (not supplied) adjacent to the battery box and fit a suitable waterproof coupling to allow cable entry from the terminal box to the battery box.

5.2.4 Battery Installation

The T1200B battery box will hold 2 x 3.2Ah or 2 x 7Ah batteries, the T1200B-C battery box will only hold 2 x 17Ah batteries. Battery type is PowerSonic SLA batteries.

1. Remove the battery clamps from the battery box before fitting the batteries.
2. Place the left-hand battery into the battery box. The battery should be located toward the left side of the enclosure. For the T1200B the battery terminals should be towards the left side of the enclosure. For the T1200B-C the battery terminals should be positioned towards the front.
3. Place the right-hand battery into the battery box. The battery should be located toward the right side of the enclosure. For the T1200B the battery terminals should be towards the right side of the enclosure. For the T1200B-C the battery terminals should be positioned towards the front.
4. Fix the battery retaining clamps. [See Figure 2 and Figure 3].

5.2.5 Battery Connection

1. Connect the black battery lead to the terminal marked BAT-, connect the red battery lead to the terminal marked BAT+.
2. The Thermistor assembly is supplied loose in the fixing kit supplied with the panels. Connect

the Thermistor leads to the terminals marked THERM.

3. The blue battery lead is used to connect the two batteries together. Do not connect this until you are ready to power up the panel.

5.2.5.1 Connecting the battery box to the panel PSU

T1204DC:

1. Run a suitable 4-core shielded cable between the panel and the battery box.
2. Label each core appropriately (BAT+, BAT-, THERM, THERM).
3. Connect the negative battery conductor to the “Batt -” [battery negative] terminal and connect the positive battery conductor to the “Batt +” [battery positive] terminal. Both terminals are situated on the separate PS40 power supply board located under the C1626 motherboard.

T1204A1/A2:

1. Check and confirm the polarity of the conductors in the cable running to the T1200B battery box.
2. Connect the negative battery conductor to the “Batt -” [battery negative] terminal and connect the positive battery conductor to the “Batt +” [battery positive] terminal. Both terminals are situated on the C1626 motherboard.

T1216-C, T1232-C:

1. Check and confirm the polarity of the conductors in the cable running to the T1200B-C battery box.
2. Connect the black battery lead to “Batt -” [battery negative] terminal and connect the red battery lead to “Batt +” [battery positive] terminal. Both terminals are situated on the panel chassis.

Thermistor connections within the fire alarm panel:

1. Connect the Thermistor leads as follows:
2. T1204A1/A2: To the two terminals marked “Therm” on the C1626/C1627 motherboard.
3. T1204DC: To the two terminals marked “Thermistor” on the PS40 PSU.
4. T1216-C, T1232-C: To the two terminals marked “Therm” on the panel chassis.
5. Tie-wrap the Thermistor to one of the battery leads so that when the battery leads are connected, the Thermistor is located just above one of the batteries.
6. Warning: Do not connect the leads to the battery at this stage. On the T1204DC, T1216-C and T1232-C connection of the batteries will power up the panel even if the mains supply is off.

T1200-C

MARINEC-P-I

1 11/12

5.2.6 Installation and connection of the C1631 Repeater Interface

Warning: Observe anti-static precautions

The C1631 interface board is not provided as standard with the panel. It is included in the spares kit of the repeater panel, to be fitted in the main fire alarm panel when required.

1. Ensure that the panel and repeaters are powered down and the main and standby supplies are disconnected.
2. On the fire alarm panel remove the jumper link at J22 (adjacent to J9) and fit a C1631 repeater interface to connectors J13 and J9 on the right-hand side of the C1626/C1627 motherboard. The board should be held in place by the 12mm high plastic spacer provided. See Figure 8 and Figure 9.
3. The Repeater is supplied with the C1631 Interface Board fitted.
4. Connect the RS485 data cable as shown in Figure 4.
5. Connect the Aux 24Vdc supply from the panel to the repeater. You can use two cores in the

data cable for this purpose only if the voltage drop between the panel and repeater is not more than 2Vdc.

Notes:

One repeater will draw up to 75mA which means that the total resistance of the cable should not exceed 24 Ohms (12 Ohms in each core). The T1200-C Application Guide lists cable types with their nominal DC resistance.

If more than one repeater is required or the cable resistance is too great, then data cable is unsuitable for supplying power and a separate suitable 2-core cable must be used.

Use only Plenum rated screened data cable with at least 3 pairs to accommodate repeater communication & Muster Interface options. 4 pairs will be required if power is also being provided (subject to the limitations described above).

Connect the cable screen to earth at the fire alarm panel and the repeaters.

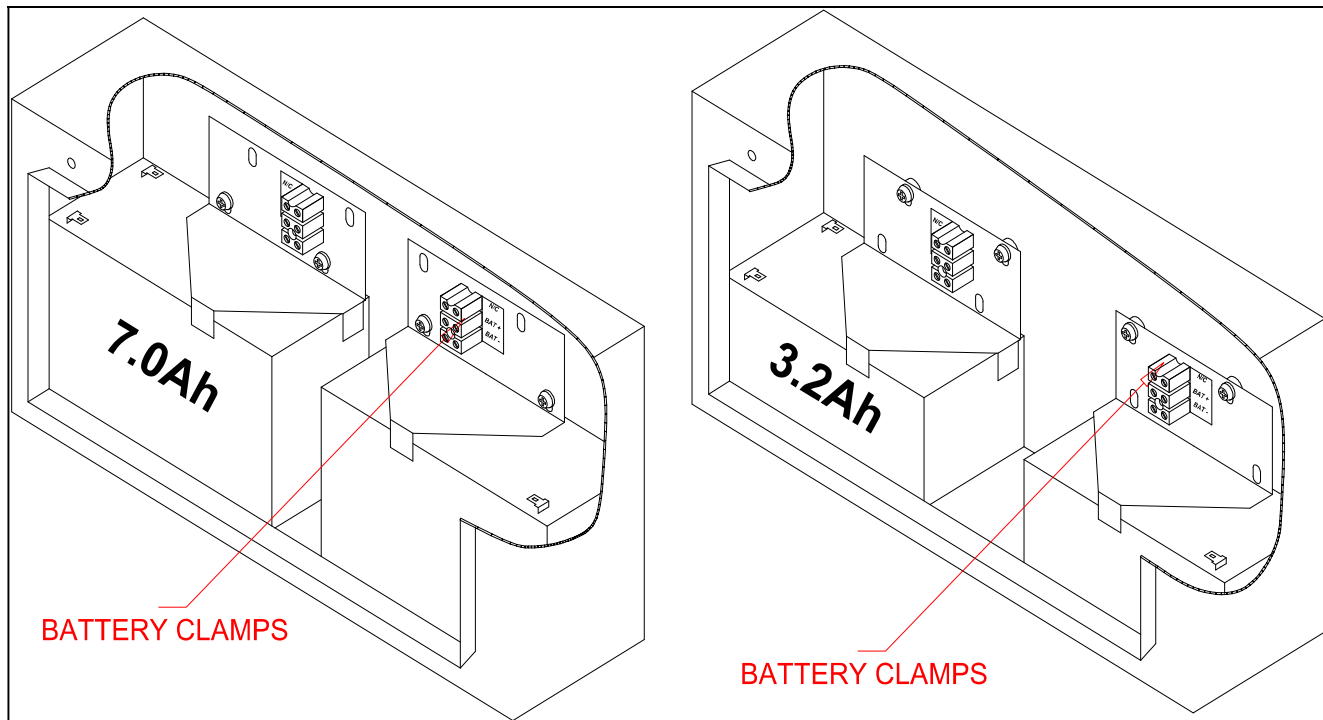

Figure 2 – Battery clamp details - T1200B

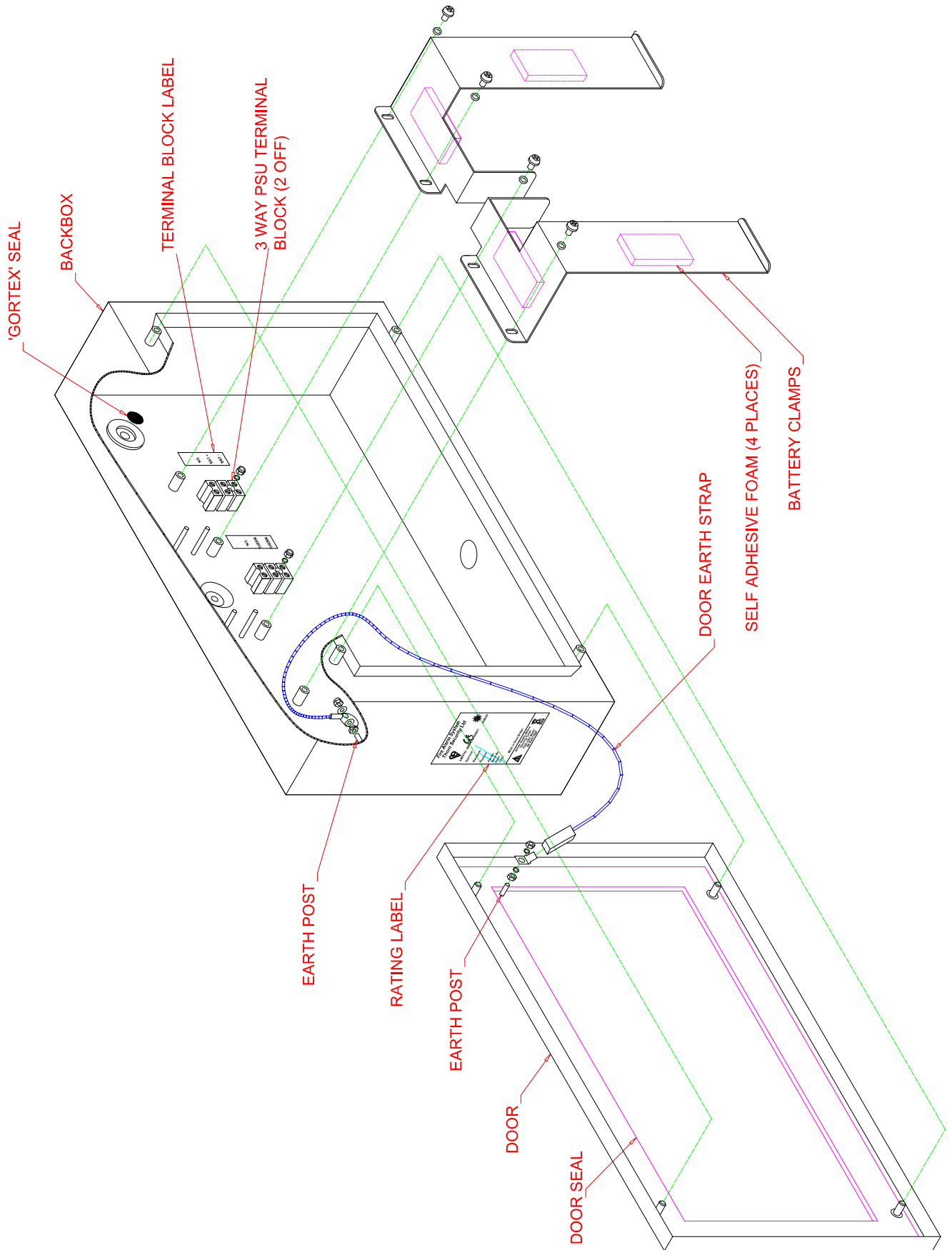

Figure 3 – Battery clamp details - T1200B-C

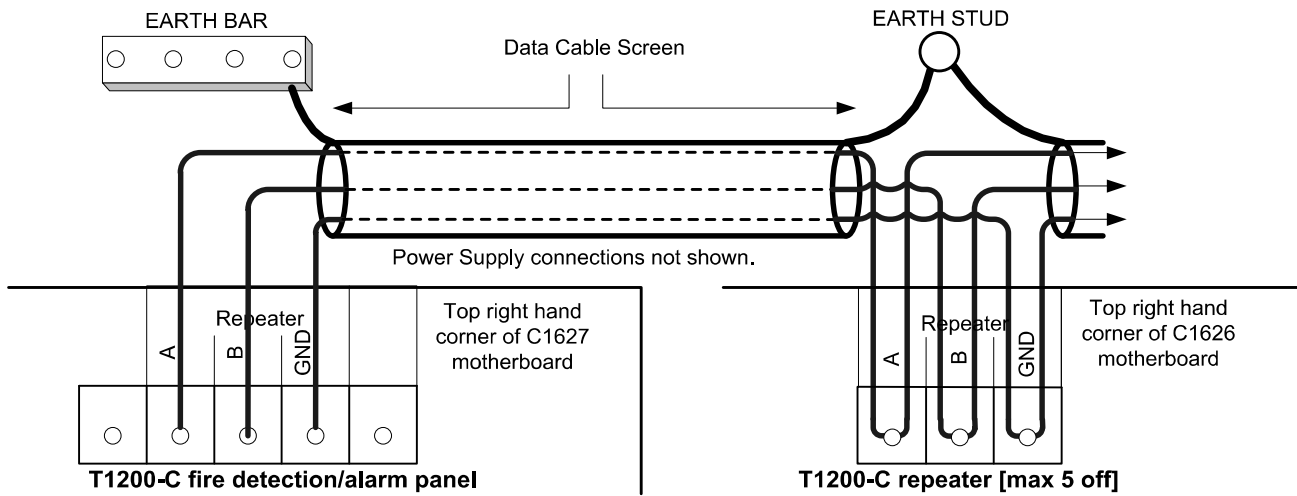

Figure 4— Repeater connection diagram

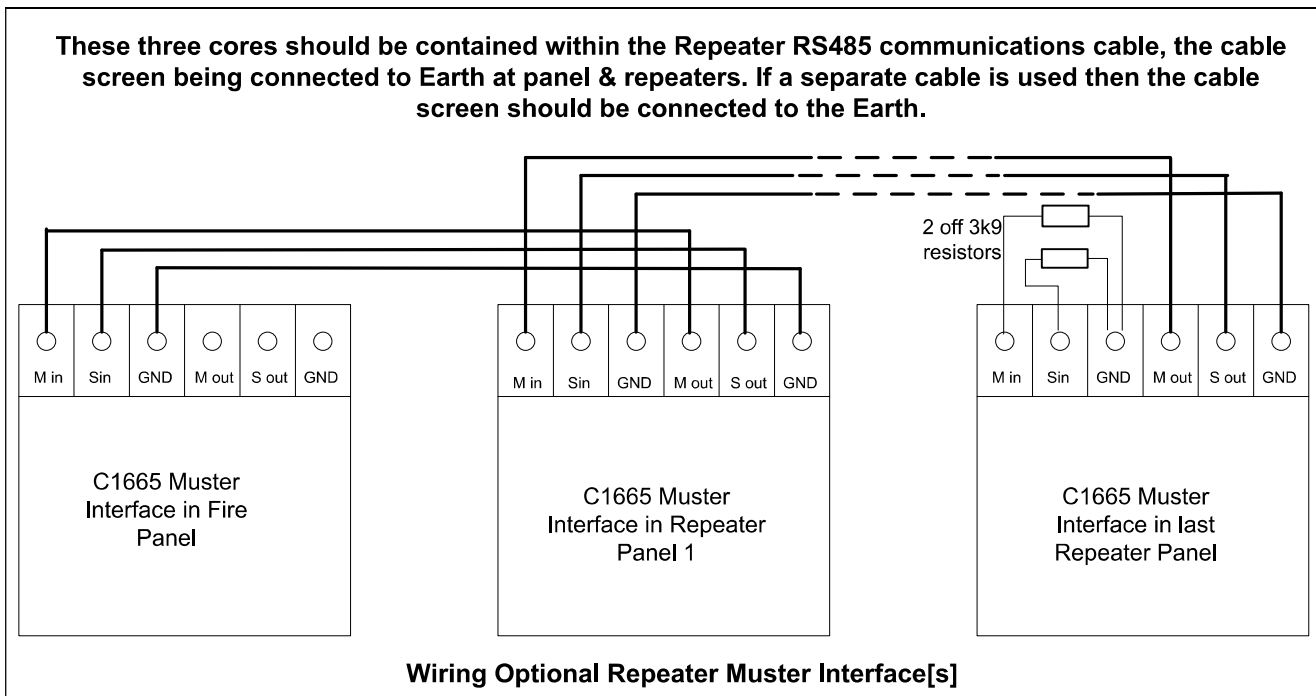

Figure 5— Muster Interface Wiring Diagram

5.2.7 Installation and connection of the C1665 Muster Interface

Warning: Observe anti-static precautions

1. The C1665 interface board is not provided as standard with the panel. It is an optional item that can be ordered separately and used with repeaters to provide Muster Alarm control from repeater panels.
2. Ensure that the panel and repeaters are powered down and the main and standby supplies are disconnected.
3. On the C1626/C1627 motherboard in the fire alarm panel and each repeater, identify link

- J23 and connector J2 which are located on the left hand side of the motherboard.
4. Remove link J23 and carefully plug the C1665 PCB into connectors J2 and J23.
5. Connect the field cable as shown in Figure 5.
6. Connect 2 off 3k9 monitoring resistors to the C1665 in the last repeater as shown in Figure 5. [The resistors are supplied in the Muster Interface fixing kit].
7. On the fire alarm panel display PCB [C1628 or C1629], fit link J2 to the lower position for Muster operation.
8. Note: Use three cores of the RS485 screened data cable.

5.3 Replacing the Display Inserts

The display overlay is adhered to the display PCB and is fitted with a series of text label inserts to identify the various user controls and indications. The inserts slip into pockets in the overlay and provide a flexible method of providing foreign language variants without affecting the overlay. The panel is provided with one set of standard English text inserts fitted. These inserts are reversible and the reverse side is blank to allow small volume language variants to be typed. Since one of the panel's configurable options allows manual activation of the fire alarms in either the Manual Fire Alarm or Muster mode, an additional English text insert is provided for the switch section – one side identifies the top left hand switch and LED as "Manual Fire Alarm" the other side identifies this switch as "Muster".

Additional double sided inserts can be supplied for Chinese or Japanese applications.

5.3.1 To change the inserts

1. Isolate the mains supply to the panel.
2. Disconnect the batteries at the battery box.
3. The buzzer in the panel will sound continuously due to total loss of power. Open the panel door.
4. Locate and disconnect the wire from the 9V battery holder at J4 on the back of the display board (bottom-centre). [The PP3 battery is fixed to the display frame below the display board]. The buzzer will silence.
5. Disconnect the buzzer lead from the display board (either connected at the bottom (J5) or top (J6)).
6. Use an M3 box spanner to loosen and remove the nuts and plain washers holding the display frame. Store the nuts and washers safely for re-fitting.
7. If the optional Door Stay is fitted then this will need to be removed from the frame (see section 5.3.2).
8. Remove the frame and store it safely.
9. To separate the display from the seal, carefully apply moderate pressure to the front of the display at the perimeter of the board near the edge of the hole in the door. Work progressively from the starting point around the edge of the PCB back to the starting point.
10. When the display PCB is free of the seal, remove the PCB from the door studs. Carefully work the PCB off the studs keeping the PCB parallel to the door to prevent it jamming.
11. The insert tabs can clearly be seen projecting from the edge of the PCB. Pull the tabs carefully to remove the inserts.
12. To re-fit an insert, locate the gap between the PCB and the overlay and slide a corner of the insert in. Straighten the angle of entry, hold the insert near the point of entry rather than at the end and feed the insert down until the leading edge of the insert is fully home.
13. Visually inspect the front of the display to ensure the inserts are correctly aligned.
14. Re-fit the display board to the studs on the door, making sure that the display is the correct way up.
15. Work the display board down the studs keeping the board parallel to the door to prevent jamming.
16. When the board is down on the studs, apply light pressure around the outside edge of the board to ensure it is correctly seated on the seal.
17. Refit the frame with the battery located towards the bottom of the door.
18. When the frame is fully down on the studs, apply light pressure around the outside edge to ensure it is correctly seated.
19. Refit the washers to all studs and then fit the nuts loosely only.
20. Using the box spanner, carefully tighten each nut down until it is just in contact with the frame. Do not fully tighten at this stage.
21. Tighten each nut by turning the nut a quarter of a turn. Press the frame against the enclosure door using fingers only and check for any slack.
22. Repeat step 21 until the frame is firmly seated.
Note – Over-tightening the nut may cause the stud to break away from the door.
23. Refit the Door Stay if previously removed.
24. Reconnect the buzzer lead to J5 or J6 as appropriate.
25. Reconnect the 9V battery lead to J4 on the rear of the display PCB. The buzzer will sound.
26. Close the panel door.
27. Reconnect the standby batteries at the battery box.
28. Re-instate the mains supply to the panel. After a few seconds the panel will return to the quiescent state.

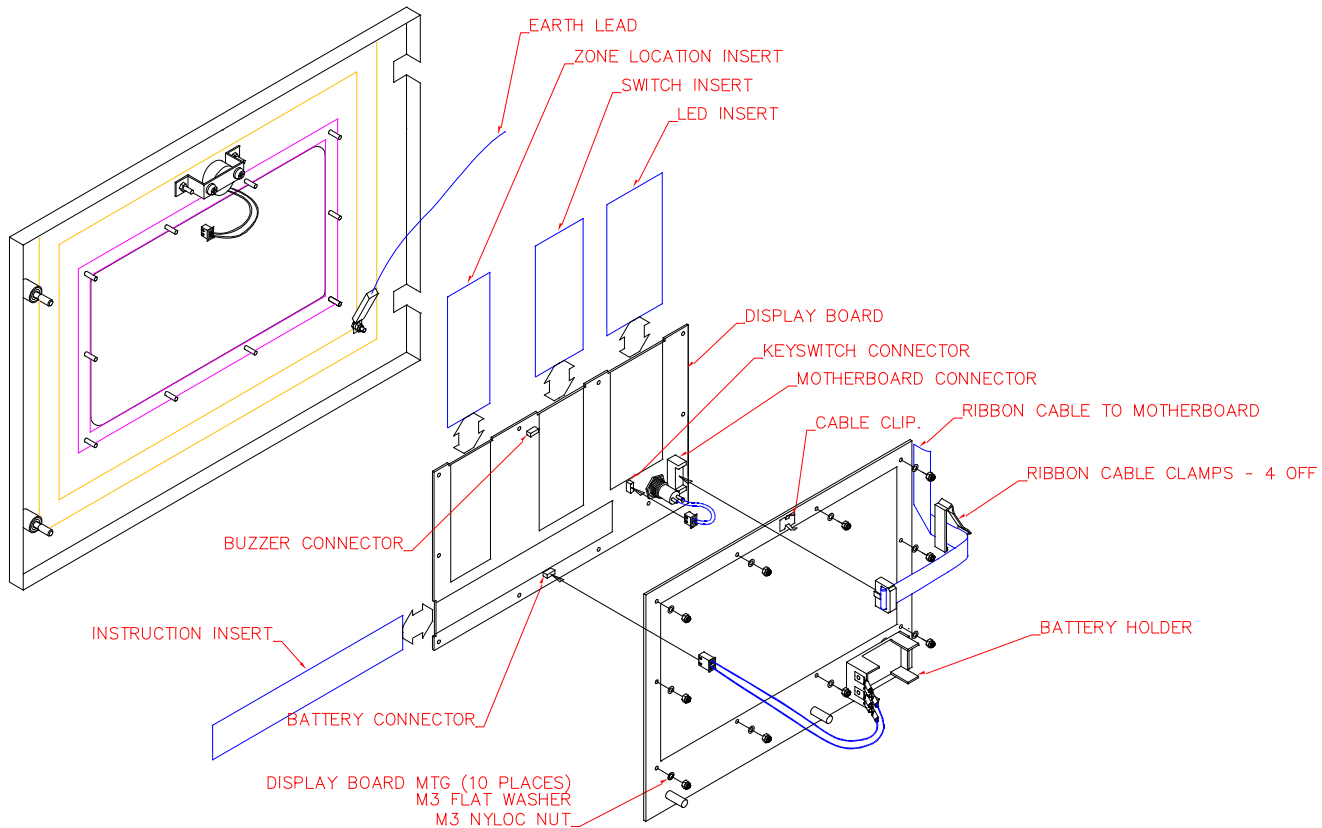

Figure 6 – Display Insert Replacement

5.3.2 To Fit the Optional Door Stay

1. A door stay is available as an option for the panels listed below.
T1216-C, T1216W-C, T1232-C, T1216R-C
T1232R-C, T1200E-C.
2. A single door stay may be fitted to the door/back box assembly during the installation of the panel enclosure described in section 5.2.1. Also refer to Figure 7 – Door Stay Assembly. Note that it will be very difficult to fit the door stay with the motherboard chassis in the enclosure.
3. Materials required – 1 off T1200 Door Stay Assembly kit [508.023.025].
4. Tools – ratchet socket set with 8mm and 10mm sockets.
5. Locate the four fixing studs used to secure the stay. Two M6 studs are located on the frame holding the display board. These are used to secure the door mounting bracket. Two M5 studs are located on the inner return face of the back box at the bottom towards the door hinge. These are used to secure the door stay enclosure mounting bracket.
6. Offer the door stay door mounting bracket up to the studs on the display frame as shown in Figure 7 and fit one M6 washer and Nyloc nut [supplied] to each stud. The nuts should be tight enough to prevent movement between slider assembly and door.
7. Adjust the door opening angle and the orientation of the Door Stay arm so that the enclosure mounting bracket can be fitted to the studs on the enclosure. Secure with the M5 nyloc nuts provided. Tighten the nuts sufficiently [with an M5 socket] to prevent any movement between the bracket and the box.
8. Check the operation of the Door Stay. The door should open to approximately 110-120 degrees allowing the sliding nut to drop into the latched position latching the door open. To close the door, push the Door Stay arm up to release the door stay sliding assembly nut.

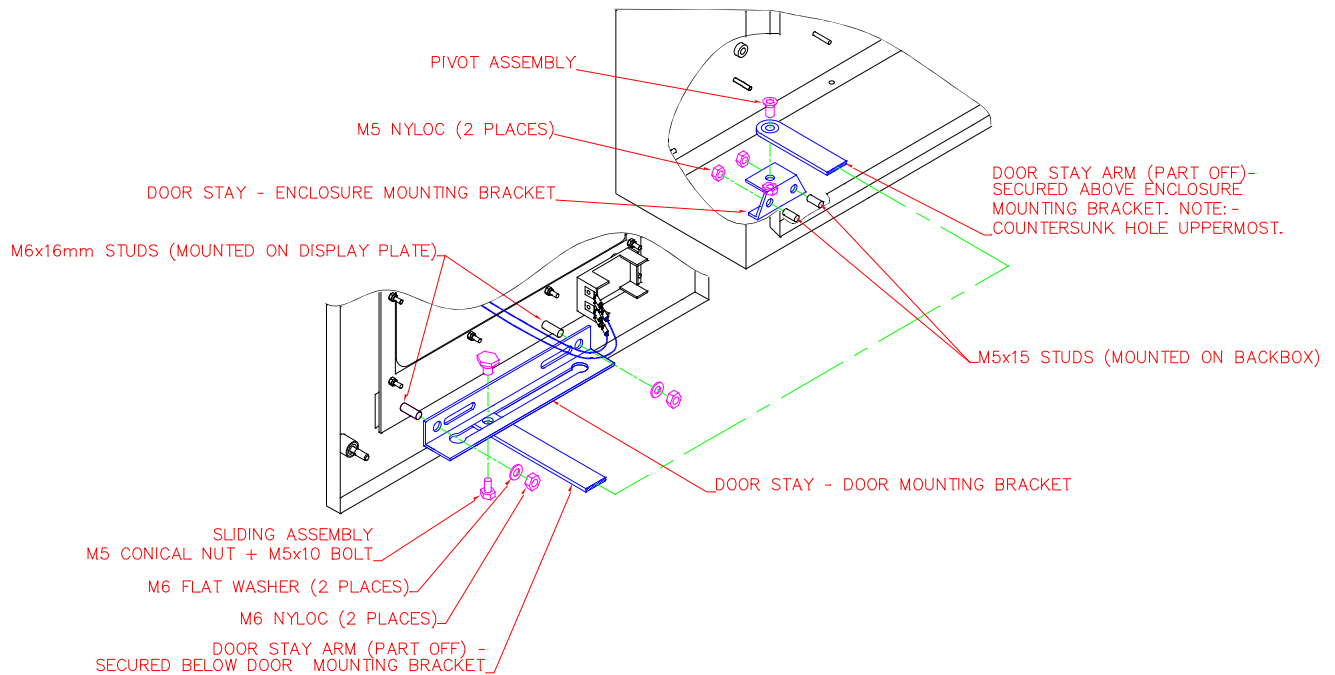

Figure 7 – Door Stay Assembly

6. Commissioning

6.1 Introduction

The following equipment should be available where possible to minimise commissioning time:

- i. VHF/UHF Portable Radio or other communication device (for two engineers).
- ii. Digital Multi-meter with accurate voltage & resistance measuring capabilities.

6.2 Commissioning Checklist

1. Before commissioning, the engineer should check the following:
 - (a) All field wiring has been inspected and tested in accordance with manufacturer's wiring recommendations and all relevant marine/local regulations.
 - (b) All field cables are wired into the control panel enclosure through suitable cable glands.
 - (c) Detector bases are terminated but detector heads are not fitted. Any devices with electronic components are not fitted. Terminations to devices with electronic components should be linked through to maintain cable continuity.
 - (d) Manual Call Points are not connected but cable is linked through to maintain continuity.
 - (e) No end-of-line devices (e.g. alarm circuit EOL resistors) are fitted in the field.

2. The following information should be available to the commissioning team:

- Detection layout drawings.
- Wiring schematic diagram.
- Control Panel installation manuals.
- Installation manuals for all equipment connected to the system.
- Vessel specific configuration details.

Experience has shown that tracing wiring faults on long circuits that are routed through risers etc. can be difficult without knowledge of the wiring route.

It is recommended that the electrical installer be made available until basic wiring continuity is proven.

6.3 An Overview of the Commissioning Procedure

Commissioning is broken in to 3 sections:

1. Pre-commissioning wiring check.
2. Powering the panel up with no field wiring connected, configuring the panel in accordance with the vessel-specific requirements and carrying out a functional check.
3. Functional testing of all circuits and field devices to check each circuit and function in turn to ensure correct operation of the entire system.

In this way any faults may be located quickly and accurately. The general procedures are as follows:

1. Alarm circuits should be checked first by using the Manual fire alarm/Muster function. The correct operation of each sounder should be

T1200-C

MARINEC-P-I

1 11/12

checked to ensure that audibility levels meet the relevant regulations.

2. Detection zones should be commissioned next. The purpose is to establish the correct functioning of each device and check for correct indication at the control panel. The panel responses [as configured] should be checked at this time.
3. All ancillary inputs and outputs should be commissioned and the functionality confirmed.
4. Fire protection signals should be tested.
5. Fire and fault output signalling should be tested.

WARNING: Before testing, the engineer must be aware both of the operation of all equipment fitted to the auxiliary circuits and of the consequences of their operation.

6.4 Pre-Commissioning Wiring Check

NOTE: This pre-commissioning wiring check procedure should be followed to test all wiring prior to specific commissioning of any detection, alarm and auxiliary circuits.

1. Ensure that no devices are connected to the detection zones and alarm circuits, but that the cables are linked through at the device locations to achieve a continuous circuit.
2. Ensure that the resistance of all cables to earth and between cores is at least $2M\Omega$.

Check the following:

- i. Positive to earth resistance is $2M\Omega$ or greater.
 - ii. Negative to earth resistance is $2M\Omega$ or greater.
 - iii. Positive to negative resistance is $2M\Omega$ or greater.
3. Connect a wire link as the end-of-line device on each of the zones and alarm circuits. At the panel end, measure the resistance across the positive & negative ends of the cables for each of the circuits; ensuring the value does not exceed 20Ω . Remember to remove the wire links after the tests.

Correct polarity throughout all circuits must be maintained. Check and rectify any faults.

4. All sounders, detector heads and call points should now be connected and the correct end-of-line devices fitted. Use the spare end-of-line devices supplied and leave the EOL devices in the panel terminals at this stage. Remember to remove any links fitted to detector bases. Be very careful to maintain correct polarity at each device.

Warning:

Intrinsically safe zone arrangement:

1. Ensure that the installation has been carried out in full accordance with the installation documentation provided with the I.S. devices and I.S. barrier. Failure to carry out the installation correctly is likely to render the system unsafe and risks causing an explosion.
2. End-of-line resistors with a value of $10k\Omega$ must be used. Additionally, these resistors must also comply with the requirements laid down in the installation data sheets provided with the I.S. barrier and the I.S. fire detection devices.
3. Any zones used for I.S. applications must be configured to Intrinsically Safe mode. [Except for mixed I.S./Non-I.S. zones as detailed below].
4. Recommended I.S. barrier - MTL5061 or MTL5561 [galvanic type].
5. Mixed I.S and Non-I.S. Zones:

Where the Safety System Documentation allows, zones can contain I.S. and Non I.S. devices. The requirements of the Safety Documentation must be applied and the number of I.S. devices must be limited to 3 in total.

The I.S. devices must be located at the end of the zone with the I.S. barrier located in an adjacent safe area. All of the non-I.S. devices must be connected in the zone wiring between the barrier and the panel. The I.S. devices should be connected between the I.S. barrier and the end of line. The zone must be configured to the non-I.S. mode [This simply sets the operating detection thresholds and is not a safety issue].

The non-I.S. section [safe side - between the panel and the I.S. barrier] will support full open and short circuit fault monitoring and detector/MCPs fire event discrimination. The I.S. section (hazardous side - between the IS barrier and the end of line resistor) will support open circuit fault monitoring only - short circuit fault will raise a detector fire. It will not support detector/MCP discrimination - all devices will raise a detector fire indication.

Intrinsically Safe alarm devices [sounders] may be connected via an MTL 5021 or MTL5521 galvanic isolator. There are no requirements for configuring the panel's sounder outputs. **Note: Galvanic isolators prevent fault monitoring of the sounder circuit in the hazardous area due to the low monitoring voltage used. Any cable fault between the isolator and I.S.**

sounders will not be detected by the panel. The 3K9 end of line monitoring resistor should be connected across the barrier terminals on the **safe** side (11 and 12 on the MTL 5021 or MTL5521) [i.e. in parallel with the sounder circuit input to the safe area terminals on the IS barrier]. The installation requirements supplied with the I.S. barrier and the I.S. sounders must be fully observed.

6.5 Powering up

Prior to powering up, the panel will have been installed in accordance with the installation instructions, all cabling will have been fully installed and tested, glanded into the panel enclosure but not connected to the panel terminals. The mains supply should be isolated externally to the panel.

1. Connect the 9V battery lead to J4 on the rear of the display PCB.
2. Connect the buzzer lead to J5 or J6 as appropriate. The buzzer will sound.
3. Check the 24V battery connections are correct.
4. Final battery connections:
 - Fit the connector on the end of the black lead onto the negative (black) terminal of the left-hand battery. Fit the connector on the end of the red lead onto the positive (red) terminal of the right-hand battery.
 - Connect the blue battery lead between the positive (red) terminal of the left-hand battery and the negative (black) terminal of the right-hand battery.
5. Ensure the mains supply is safely isolated external to the panel. Remove the mains supply fuse from the panel mains terminal block. Once the permit to energise the mains supply is in place, energise the mains. At the mains terminal block in the panel, use a multi-meter to check that the voltage and polarity are correct. Isolate the mains supply again before replacing the panel fuse and finally re-energising.
6. If all the end of line devices are correctly terminated in the panel and the 24V battery is correctly wired, the panel should be silent (after a few seconds), displaying only the Power Supply On indication.
7. Turn the Access keyswitch to "1" and press the Test Display button. The panel should respond by lighting all indications and sounding the

buzzer. This will continue for 5 seconds after the button is released.

6.6 Configuration

6.6.1 Basic Default Configuration

When first powered up, the T1200 can be operated in the standard default mode without any additional configuration.

The basic default mode is:

1. All zones latching fire, standard [non-intrinsically safe].
2. Machinery space zones – none programmed.
3. Fire output signal, Fire Protection and Sounder outputs not delayed.
4. Sounders – General steady Alarm mode selected (not zonal, not pulsed).
5. Crew Alarm Mode – not selected.
6. Fire Output – link selected to powered (monitored) mode.
7. Fire Protection Output – link selected to powered (monitored) mode.
8. Fault Signal Output – link selected to powered (monitored) mode.
9. Earth fault monitoring – enabled [link fitted].
10. Manual fire alarm/Muster sounder operation – link selected to Manual Fire Alarm.
11. LED brightness – highest setting.
12. Fire Protection output not to operate on non latched zones – not selected.
13. Inhibit silence alarms/reset for 3 minutes – not selected.
14. Silence alarms before reset – not enabled.
15. Buzzer – enabled.
16. Latching faults – not selected.

6.6.2 Vessel-Specific Configuration

It is possible to tailor the functionality of the T1200 fire alarm panel in line with vessel-specific requirements. Details of the vessel configurable options and the configuration process are provided in sections 6.6 and 7.1 respectively. Charts are provided in the System Log Book for planning/recording the actual configuration. This configuration is not lost when the panel is powered down.

7. Operating the Engineer's functions

7.1 Engineer's Zone/Output Configuration Process:

Various programmable configuration options associated with the zonal inputs and outputs can be enabled & disabled by operating the appropriate

T1200-C

MARINEC-P-I

1 11/12

DIL switch located within the panel enclosure. These are:

1. Configure zones for use with I.S. barriers or isolators.
2. Configure zones as latching/non-latching fire indication.
3. Configure outputs to be delayed.
NOTE: The delay feature does not comply with the requirements of EN54-2.
4. Configure Machinery Space Zones.

7.2 Zone or Output Configuration

1. Select a programmable configuration mode:

- Enable the controls on the display by turning the Access keyswitch on the panel display to the “1” position.
- If the panel is in the fire alarm condition, silence the alarms and reset.
- Open the panel door and locate the appropriate DIL switch on the motherboard [**Config Non-latch Zones; Config I.S. Zones; Config M/S Zones; Config Delay O/Ps**] and move the required switch to the ON position.
 - The **CONFIG ENABLED** LED on the motherboard will illuminate. If the LED pulses then an invalid configuration option has been selected.
 - The Panel’s **System Fault** LED will flash and the buzzer will operate.
 - The Select LED on the front of the display will pulse unless an invalid configuration option has been selected.
 - Any standing fire or fault alarm indications and associated outputs will be inhibited.
 - If active, the indications for evacuation, silence buzzer, delay on or disablement indications will clear.
 - The panel will indicate the current status of the selected programmable configuration mode on the yellow **fault/disabled** LEDs on the Zones, Sounders, Fire and Fire Protection outputs.

A steady indication denotes that the zone/output is already configured to the selected mode.

No indication denotes that the zone/output has not been configured to the selected mode.

- Close the panel door to allow access to the buttons on the display.

2. Select a zone or output to be configured:

- On the panel display, press the Select On/Off switch to enable the Cursor Select Mode.
 - The Select LED will become steady and the panel buzzer will silence.

- A pulsing indication [cursor] will appear either on the Zone 1 Fault/Disabled LED or the Sounder Fault/Disabled LED/Test depending upon which configuration DIL switch is selected.
- Use the Select ↑ and Select ↓ buttons to scroll the cursor indication through the selectable options:
 - For zonal configuration, through all zones sequentially in forward [Select ↓] or reverse [Select ↑] sequence starting at zone 1.
 - For Output Delay configuration, through Sounders, Fire Protection and Fire outputs in forward [Select ↓] or reverse [Select ↑] sequence starting at Sounders.

3. To change the configuration of a selected zone or output:

With the cursor flashing on the selected zone or output:

- Operation of the ENABLE button will set the configuration for the selected zone/output, causing the associated fault/disabled LED to illuminate steady (with flashing cursor).
- Operation of the DISABLE button will clear the configuration from the selected zone/output and restore normal operation. The fault/disabled LED will clear (with flashing cursor).

Move the cursor to each required zone/output in turn and press ENABLE or DISABLE as required.

4. To quit the programmable configuration mode:

To return the panel to normal operating mode applying the updated configuration:

- Open the panel door and return the selected **Config** DIL switch on the motherboard to the OFF position.
- The **CONFIG ENABLED** LED on the motherboard will clear, the panel buzzer will silence and the flashing System Fault indication and zone/output configuration status indications on the display will clear as will the cursor and the Select indications. Any current alarms, disablements, will be re-indicated along with any active status indications [Delay on etc.].
- Close the panel door.
- Return the ACCESS keyswitch to the “0” position to disable the controls on the display.

IMPORTANT NOTE: WHILE THE PANEL IS IN THE ENGINEER’S ZONAL/OUTPUT CONFIGURATION MODE, ALL ZONAL INPUTS ARE DISABLED AND OUTPUTS ARE INHIBITED – THE PANEL WILL NOT RESPOND TO ANY FIRE ALARM.

7.3 To Restore the Factory Default

Configuration for Zones & Outputs:

- Open the panel door and locate the DIL switches SW1-4 to SW1-8 on the motherboard [Config Non-latch Zones; Config I.S. Zones; Config M/S Zones; Config Delay Zones; Config Delay O/Ps] and move each switch to the On position.
 - The Config Enabled LED on the motherboard will flash.
 - The Panel's System Fault LED and Disabled LED will flash and the buzzer will operate.
 - Any standing fault or disablement indications will clear.
 - It will not be possible to enter the Select Mode.
- Press the Disable button on the panel's display and wait 5 seconds.
- Return DIL switches 1-4 to 1-8 to the OFF position.
 - The Config Enabled LED on the motherboard will clear.
 - The Panel's System Fault LED will flash and the buzzer will clear.
 - The factory default configuration [all zones as latching fire, non-intrinsically safe, not machinery space] will be restored and the Fire output, Fire Protection and Sounder outputs will no longer be delayed.

7.4 Engineer's Zone/Output

Configuration Time-out Warning:

This feature is provided to prevent the panel being left in the Zone/Output Configuration condition.

- 1 minute after the last button press:
 - The panel buzzer will restart.
 - The Select LED will flash.
 - The System Fault LED will continue flashing.
- Press the Select On/Off button to continue with the configuration process otherwise quit the configuration process as described in step 4 of 7.2 above.

7.5 Invalid Configuration conditions:

- Invalid condition: If two or more configuration switches on the motherboard are in the ON position at the same time:
 - The Config LED on the motherboard will flash.
 - The System Fault and Select LEDs on the display will flash.
 - The fault relay will operate.
 - The panel buzzer will sound.
 - The Cursor indication will clear.

- Configuration will be inhibited.

- To clear the invalid condition check the zone and output config switches [1/4, 1/5, 1/6, 1/7, 1/8] on the motherboard and ensure that only one is selected to ON.
- Invalid condition: Selecting any config mode switch [1/4, 1/5, 1/6, 1/7, 1/8] to the ON position whilst the panel is in the fire condition.
 - The Config LED on the motherboard will flash.
 - The System Fault and Select LEDs on the display will flash.
 - The panel buzzer will sound.
 - The Cursor indication will clear.
 - Configuration will be inhibited.
- To clear the invalid condition, select the config switch to OFF. Reset the fire alarm condition before attempting the configuration process again.

7.6 List of configuration DIL switches and their functions

• SW 1/1 - Inhibit F/P on NLZ:

Selects Fire Protection relay to operate **or** not to operate for a fire condition on any zone configured to non-latched mode.

- OFF Fire Protection relay operates for a fire condition on any zone.
- ON: Fire Protection relay does not operate for a fire condition on any zone configured to non-latched mode.

- [Not EN54 compliant function].

• S/W 1/2 - Delay Alarm Sil & Rst:

- OFF: Silence and reset available at all times.
- ON: Prevents alarms being silenced or reset for a period of 3 minutes after a fire alarm condition occurs.

- [Not EN54 compliant function].

• SW 1/3 - Delay ON Auto:

- OFF: Configuration mode disabled.
- ON: Enables Coincidence on paired zones for Water-Mist Panel use.

• SW 1/4 - Config Non-Latch Zones:

- OFF: Configuration mode disabled.
- ON: Enables selected zones to be configured to non-latching fire mode via the Engineer's Select feature.

- [Not EN54 compliant function].

• SW 1/5 - Config I/S Zones:

- OFF: Configuration mode disabled.
- ON: Enables selected zones to be configured to Intrinsically Safe alarm thresholds via the Engineer's Select feature. [For use with

T1200-C

MARINEC-P-I

1 11/12

appropriate I.S. galvanic barriers. Type MTL5061/MTL5561].

- **SW 1/6 - Config M/S Zones:**

- OFF: Configuration mode disabled.
- ON: Enables selected zones to be configured as Machinery Space zones via the Engineer's Select feature.

- **SW 1/7 - Not used.**

- **SW 1/8 - Configure Delay O/Ps:**

- OFF: Configuration mode disabled.
- ON: Enables the selection of outputs, via the Engineer's Select feature, to which the panel delay will apply.

NOTE: This feature does not comply with the requirements of EN54-2.

- **SW 1/9 - Not used.**

- **SW 1/10 - Alarms on Evac Only:**

- OFF: Sounders operate on any fire condition including manual fire alarm/muster.
- ON: Selects sounders to operate only when the panel is in the manual fire alarm/muster condition.
- [Non-EN54 compliant function].

- **SW 2/1 - Silence Before Reset:**

Selects the type of reset mode.

- OFF: Reset available when panel is in the [un-silenced] fire or fault condition.
- ON: Fire Condition Reset available only when panel is in Alarm Silenced condition. Fault reset available when panel is in the fault condition. (Not permitted under EN54-2).

- **SW 2/2 - Pulse Alarms:**

Select type of sounder Operation.

- OFF: Sounders will be continuous.
- ON: Sounders will pulse.

NOTE: Muster Alarms will override any configuration settings.

- **SW 2/3 - Restart Delay:**

Select type of Delay response in **Crew Mode only**.

- OFF: If Sounders are silenced before the end of the 2-minute delay, a new fire condition will immediately operate all delayed outputs without delay.
- ON: If Sounders are silenced before the end of the 2-minute delay, a new fire condition will restart the delay timer.

- **SW 2/4 & 2/5 - Not used.**

- **SW 2/6 - Enable Zonal Alarms, SW 2/7- Pulse Non Alarm Zones:**

MODE	SW 2/6	SW 2/7
General Alarms	OFF	OFF
Crew Mode	OFF	ON
Zonal Alarms	ON	OFF
Zonal Alarms with Alert	ON	ON

- **General Alarms** – all sounders operate (continuously or pulsed – DIL SW 2/2) until silenced.

- **Zonal Alarms** – Only the Alarm circuit(s) for the zone(s) in fire will operate (continuously or pulsed – DIL SW 2/2) until silenced.

Note: Zonal Alarms mode on the T1204 panel affects the four sounder circuits on the motherboard. On the T1216-C and T1232-C panels, it affects only the expansion module sounder circuits, the motherboard sounder circuits always operate as General Alarms.

- **Zonal Alarms with Alert** – The Alarm circuit(s) for the zone(s) in fire will operate (continuously or pulsed – DIL SW 2/2) until silenced. All other Alarm circuits will pulse.

Note: Zonal Alarms mode on the T1204 panel affects the four sounder circuits on the motherboard. On the T1216-C and T1232-C panels, it affects only the expansion module sounder circuits, the motherboard sounder circuits always operate as General Alarms.

- **Crew Mode** – Sounder circuit 2 is pre-assigned to Bridge area, Sounder circuit 1 is pre-assigned to machinery space zones, sounder circuits 3 & 4 are for all other areas:

- Sounder circuits cannot be manually configured for delayed operation.

- Sounder circuit 2 on the panel control board always operates immediately on any fire alarm condition.

- Sounder circuit 1 will operate immediately if there is a fire in a machinery space zone, but will be delayed for 2 minutes for a fire on any other zone.

- Sounder circuits 3 & 4 on the motherboard and any output board sounder circuits are always delayed by 2-minutes.

- The fire Output & Fire Protection Outputs can be optionally configured to be delayed along with the sounders.

- Operation of Silence Alarms will stop the delay if operated within the 2-minute delay period, preventing all delayed outputs from operating.

- Operation of Resound alarms will clear the delay and operate all delayed outputs.

- Operation of a manual call point or the Delay Override button will clear the delay & operate all delayed outputs.
- The delay can be configured to restart for a new fire condition if the alarms are silenced within the 2-minute delay period (see SW 2/3 details above).
- **SW 2/8 - Silent Zone Test:**
Select sounder response in One Man [Detector] Test Mode:
 - OFF: Sounders operate once on each test.
 - ON: Sounders do not respond to a zone test.
- **SW 2/9 - Buzzer Disable:**
Enable/disable panel fire/fault buzzer.
 - OFF: Buzzer is enabled.
 - ON: Buzzer is disabled. General Disablement LED illuminated.

This is not compliant to EN54-2 & is provided for commissioning purposes only. The buzzer will continue to sound for a system fault or for total power failure if the 9V battery is fitted.
- **SW 2/10 - Latched Faults:**
When enabled, all fault conditions latch until the Reset switch is operated.
 - OFF: Non-latched faults.
 - ON: Latched faults.

7.7 List of Link Configuration features

Feature	Function	Link Ref	Link configuration	Link Location
Fire Output	Fault monitored/powering O/P	J10	Fitted	C1626/C1627 motherboard, to the right of the Fire [Routing] Output relay
	Volt-Free C/O relay O/P	J11 J12	Removed	
Fault Output	Fault monitored/powering O/P	J6	Fitted	C1626/C1627 motherboard, to the right of the Fault [Routing] Output relay
	Volt-Free C/O relay O/P	J7 J8	Removed	
Fire Protection Output	Fault monitored/powering O/P	J14	Fitted	C1626/C1627 motherboard, to the right of the fire protection relay
	Volt-Free C/O relay O/P	J15 J16	Removed	
Manual Fire Alarm/Muster	Manual Fire Alarm mode selected	J2	Link in upper position	On the back of the C1628 and C1629 display PCB
	Muster Alarm mode selected		Link in lower position	
	Manual Fire Alarm/Muster disabled		Link removed	
Earth Fault monitoring	E/F monitoring enabled	J18	Link fitted	Lower right hand corner of C1626 and C1627 motherboards
	E/F monitoring disabled		Link removed	

T1200-C

MARINEC-P-I

1 11/12

7.8 DIL switch settings on the Repeater Interface Board:

DIL switch SW1 on the C1631 Repeater Interface PCB is used to set the quantity of repeaters and the repeater addresses as follows:

- To set the repeater quantity, set SW1 on the C1631 fitted to the fire alarm panel in line with Table 2 – C1631 setting for quantity of repeaters.

Table 2 – C1631 setting for quantity of repeaters

SW 1	Repeater Quantity					
	0	1	2	3	4	5
1-1	Off	On	Off	On	Off	On
1-2	Off	Off	On	On	Off	Off
1-3	Off	Off	Off	Off	On	On

- To set the addresses of the individual repeater panels, set SW1 on the C1631 fitted to each repeater panel in line with Table 3 – C1631 setting for repeater addresses. Note that each repeater must have a unique address.

Table 3 – C1631 setting for repeater addresses

SW 1	Repeater Address					
	0 *	1	2	3	4	5
1-1	Off	On	Off	On	Off	On
1-2	Off	Off	On	On	Off	Off
1-3	Off	Off	Off	Off	On	On

* Note: Address 0 = repeater disabled.

7.8.1 C1630 Output Interface Configuration

The C1630 board is fitted to connectors on the C1627 board. It provides the communications path to the output expansion modules [C1633, C1634, C1635 and C1714]. The quantity and type of output expansion boards are set on DIL switches on the C1630. For the standard T1216-C and T1232-C panels, the C1630 is factory fitted and configured for the C1714 VDR output board. If further output expansion modules are to be added the configuration setting on the C1630 will need to be changed accordingly (see Table 4).

NOTE: The C1714 VDR output board is fitted as standard to the T1216-C & T1232-C panels. See Table 5 for DIL switch settings on the C1714.

Table 4 – Setting Quantity and Type of O/P Modules on the C1630

C1630 DIL Switch setting		Qty of boards	Type of board
F/P0	F/P1		C1634 or C1635 configured to FP [Fire protection Output]. See configuration details in T1200E-C Manual.
Off	Off	0	
On	Off	1	
Off	On	2	
On	On	4	
S/C0	S/C1		C1635 configured as sounder module. See C1635 configuration details in T1200E-C Manual.
Off	Off	0	
On	Off	1	
Off	On	2	
On	On	4	
LED0	LED1		C1633 open collector output module. See C1633 configuration details in T1200E-C Manual.
Off	Off	0	
On	Off	1	
Off	On	2	
On	On	4	
VDR			VDR [Voyage Data Recorder Output Module] C1714 for relay and serial data outputs.
Off		0	
On		1	

Note: Select switch to left hand side for OFF and right-hand side for ON.

Table 5 – Setting C1714 VDR Panel Number

Panel Number	PN-1	PN-2	PN-4	PN-8
0 (No serial data)	OFF	OFF	OFF	OFF
1	ON	OFF	OFF	OFF
2	OFF	ON	OFF	OFF
3	ON	ON	OFF	OFF
4	OFF	OFF	ON	OFF
5	ON	OFF	ON	OFF
6	OFF	ON	ON	OFF
7	ON	ON	ON	OFF
8	OFF	OFF	OFF	ON
9	ON	OFF	OFF	ON
10	OFF	ON	OFF	ON
11	ON	ON	OFF	ON
12	OFF	OFF	ON	ON
13	ON	OFF	ON	ON
14	OFF	ON	ON	ON
15	ON	ON	ON	ON

Note: The Panel number is sent as part of the message to the Voyage Data Recorder and helps to identify the panel.

7.9 Commissioning Procedure

After completion of the pre-commissioning wiring check, panel power-up and configuration steps, commission the circuits in line with the following guide.

7.9.1 Alarm Circuits

1. Remove the resistor from the first alarm circuit terminal and connect the first alarm circuit wiring to the terminals, observing correct polarity. Check that any alarm fault indications clear after a few seconds.
2. Use the Alarm Test facility [see T1200-C User Manual] or press Manual fire alarm/Muster to operate the sounders. Check that all sounders connected to the alarm circuit operate.
3. Clear the Alarms Test condition or if "Manual fire alarm/Muster" was used, press Silence Alarms to stop the sounders operating.
4. Repeat steps 1 to 3 for the second and any subsequent alarm circuits.

7.9.2 Detection Zones

Work logically and systematically through each zone.

1. Zone fault conditions:

- Remove the resistor from the zone 1 terminals and connect the cables of the zone 1 circuit to the panel terminals, observing the correct polarity. Check that any zone 1 fault indications clear after a few seconds.
- Check the fault monitoring of the cable is correct by applying an open circuit then a short circuit at the end-of-line device (in the field). Check that the fault condition is indicated on zone 1 on the fire panel.
- Remove the circuit faults, restoring the circuit to the healthy condition and confirm that the fault indication clears.

2. Zone fire conditions:

- On each zone in turn, start with the device nearest the panel and operate each manual call point and detection device on the zone.
- After operation of each device confirm:
- The fire indication is provided on the panel on the correct zone.
- The fire alarm devices operate correctly in line with the panel configuration.
- The Fire output [fire output signal] and Fire protection output operate correctly in line with the panel configuration.
- Press the Silence Alarms and the Reset buttons after each device test and check the alarm clears (Manual Call Points must be manually reset before resetting the panel).

3. Detector removal operation:

- Remove the 1st detector along the zone cable [starting at the panel] on zone 1 and check that:
 - The amber zone fault LED illuminates.
 - The internal buzzer sounds.
 - The fault relay operates.
 - Refit the detector and check that the control panel returns to the normal state.
 - Continue to test each of the other detectors in turn, checking on each removal that:
 - The amber zone fault LED illuminates.
 - The internal buzzer sounds.
 - The fault relay operates.
4. Any faults that are found must be traced and rectified before proceeding.
 5. Repeat steps 1 to 4, one zone at a time, until all the zones are commissioned.

7.9.3 Class Change Input

This is not a marine function.

7.9.4 Fire and Fault Outputs

1. Remove the resistor from the Fire Output circuit terminals and connect the field wiring to the terminals, observing correct polarity. Check that any fault indications clear after a few seconds.
2. To operate the output, initiate a fire condition on a zone. Check that the fire signal is received at the receiving station. Silence and reset the fire alarm panel to clear the output.
3. Remove the resistor from the Fault Output circuit terminals and connect the field wiring to the terminals, observing correct polarity. Check that any fault indications clear after a few seconds.
4. Initiate a fault condition on the fire alarm panel to signal a fault to the remote receiving station.
5. Confirm the receipt of the fault warning at the receiving station.
6. Open-circuit the output wiring of each circuit in turn & confirm the fire alarm panel indicates Fire and Fault Output faults appropriately.
7. Reconnect the cabling and confirm the faults clear.

7.9.5 Fire Protection Output

1. Ensure any fire protection equipment to be controlled via the Fire Protection output is locked off/safe before attempting any connection, testing or commissioning.
2. Remove the resistor from the Fire Protection output circuit terminal and connect the field wiring to the terminals, observing correct

T1200-C

MARINEC-P-I

1 11/12

- polarity. Check that any fault indications clear after a few seconds.
3. Initiate a fire condition on a zone to operate the output. Check that the fire signal operates the interface relay adjacent to the fire protection equipment.
4. Open-circuit the field wiring and confirm that the fire alarm panel indicates a Fire Protection output fault.
5. Reconnect the cabling and confirm the faults clear.
6. Final testing and commissioning of the cabling through to the fire protection equipment, including test [simulated] activation of the equipment, should be carried out at the appropriate time in conjunction with the engineer responsible for the fire protection system.

7.9.6 Ancillary inputs

Remote Silence Alarms, Reset and Evacuate [Manual fire alarm/Muster] inputs should each be tested by the activation of the remote equipment. The response should be verified for each signal.

7.9.7 Ancillary outputs

The correct operation of equipment connected to the Zone Outputs, Disablement Active, Evacuate [Manual fire alarm/Muster] Active and Buzzer Active outputs should be verified in turn by initiating a fire condition on each of the appropriate zones; disabling/enabling a zone; operating the Manual fire alarm/Muster and Buzzer Silence buttons on the panel's display.

7.9.8 Repeaters

1. Power-up the Panel. At the Repeater(s), only the "Power Supply On" LED should be illuminated.
2. At Repeater 1, turn the Access control switch to "1", and press the "Manual fire alarm/Muster" button. Check that the alarms operate and the internal buzzer operates on all repeaters.
3. Press the "Silence" button on the fire alarm panel. Check that the alarm circuits silence and the internal buzzer silences on all repeaters.
4. Repeat steps 2 and 3 for each repeater.
5. Operate a Manual Call Point on zone 1 and check for correct fire indication at each repeater.
6. Press the "Silence Alarms" button on a repeater and check that the alarms are silenced and the Zone 1 fire LED is constantly illuminated on all repeater panels.
7. Press the "Reset" button on a repeater and check that the panel and repeaters return to the quiescent state.

8. Repeat steps 5 to 7 for each zone and ensure "Silence Alarms" and "Reset" operate correctly from each repeater.
9. Set the DIL switches on the C1631 Repeater Interface card in the fire alarm panel to OFF (No Repeaters). Check that all repeaters indicate a "Comms. Fault".
10. Set the DIL switches on the C1631 Repeater Interface card in the fire alarm panel back to their previous settings and check that the repeaters return to normal.
11. Set the first repeater address to 0. Check that the panel indicates a "Repeater fault" and any additional repeaters display a steady "Comms fault" LED.
12. Set the first repeater address back to normal and check that the panel and repeaters return to normal.
13. Repeat steps 11 and 12 for any other connected repeaters.

7.9.9 Repeater Muster link [if fitted]

1. On repeater 1, select the Access Controls switch to position '1' and press the Muster button on the display.
2. Check the fire panel and the fire alarm sounders respond correctly.
3. On repeater 1, press the Silence Alarms button and check that the fire alarm panel responds correctly and the fire alarm sounders cease operating.
4. Repeat steps 1 to 3 at each repeater panel fitted with a muster interface board.
5. At the last repeater panel disconnect one of the 3k9 resistors connected to the C1665 and check the fire alarm panel reports "Repeater Fault".
6. Reconnect the resistor & confirm the Repeater Fault clears at the fire alarm panel.
7. Disconnect the other resistor and confirm the Repeater Fault at the fire alarm panel.
8. Reconnect the resistor and confirm the fault signal clears.

7.9.10 Power Supply Unit

1. Ensure that the system is fully commissioned with all output circuits loaded as required by the system design.
2. Ensure that the battery has been on charge for at least 2 hours.
3. Isolate the primary power supply feed to the panel.
4. Check the panel indicates power supply fault.

5. Enter the Test Alarms mode to load the panel.
6. Confirm that the system continues to respond correctly during the test.
7. Quit the test and restore the primary supply.

Note: The batteries may require a period in excess of 24hrs to achieve a fully charged condition.

7.9.11 Final Dressing of the Cables

Ensure that the field conductors are secure and tidy inside the enclosure. Use Tie-wraps to secure any long conductors or looms which might be prone to damage due to vibration of the panel enclosure. Check that all cables are firmly held in the terminal blocks & Earth bars. Check that the Earth Bars are firmly fixed to the enclosure. Check that all Earth leads are correctly & firmly connected. Check that End-Of-Line resistors in unused circuits are positioned in a safe manner and are unlikely to create short circuit faults due to movement. It is advised that unused EOL resistors have insulating sleeving placed on the leads for safety.

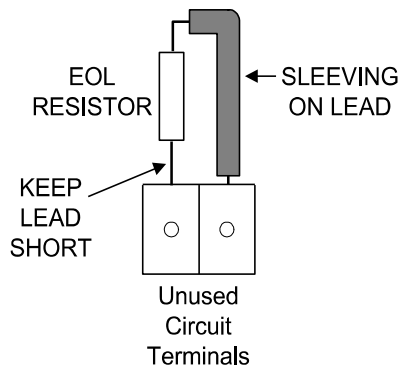

8. User Indications

General Indicator Section		
Indicator	Indication Colour	Operating Condition
Power Supply On	Green	Illuminates Steady for Mains or Standby power On.
Fire	Red	Flashes on any new fire alarm condition, changing to a steady indication on operation of Silence Alarms.
Fire Output Active	Red	Illuminates Steady when the Fire Output is active.
General Fault	Yellow	Flashes for any fault condition.
Power Supply Fault	Yellow	Flashes for mains or standby power supply/charge fault.
System Fault	Yellow	Illuminates Steady to indicate Microcontroller or Memory Failure. Flashes to indicate Engineer's Configuration Mode active.
Earth Fault	Yellow	Flashes for any positive or negative power supply earth fault.
Fuse Failed	Yellow	Flashes for any auxiliary supply fuse failure.
Repeater Fault	Yellow	Flashes for any Repeater fault or repeater communication fault.
Sounder Fault/Disabled	Yellow	Flashes for any sounder fault. Steady for sounders disabled.
Sounder Test	Yellow	Illuminates Steady while sounder walk test is active.
Fire Protection Fault/Disabled	Yellow	Flashes for a fault on the Fire Protection Output. Steady when the Output is disabled.
Fire Output Fault/Disabled	Yellow	Flashes for a fault on the Fire Output. Steady when Fire Output is disabled.
Fault Output Fault/Disabled	Yellow	Flashes for a fault on the Fault Output. Steady when Fault Output is disabled.

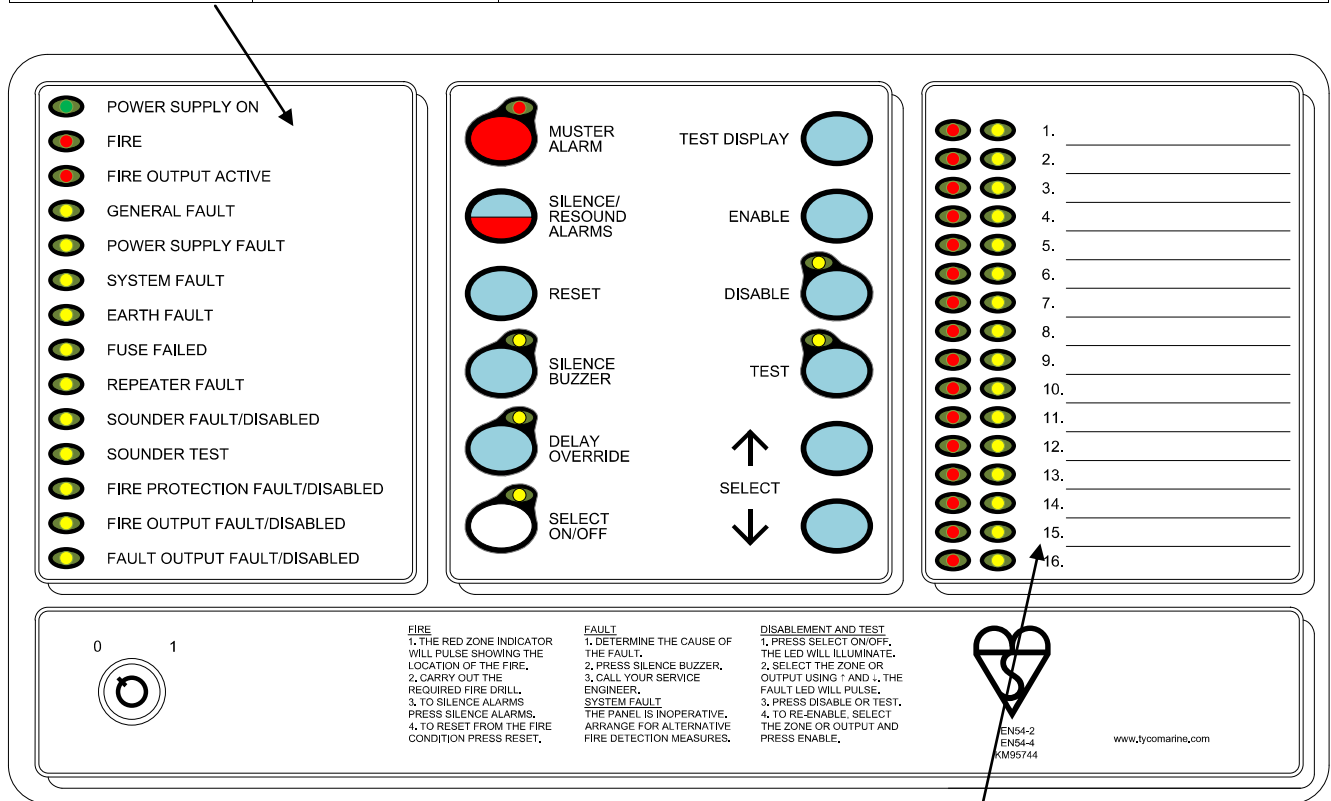

Zone Location Indications		
Indicator	Indication Colour	Operating Condition
User Generated Zone Location Text	Red	Flashes when zone is in a fire condition, turning to steady on operation of Silence Alarms.
User Generated Zone Location Text	Yellow	Flashes when zone is in a fault condition. Illuminates steady when zone is disabled or in test.

9. User Controls

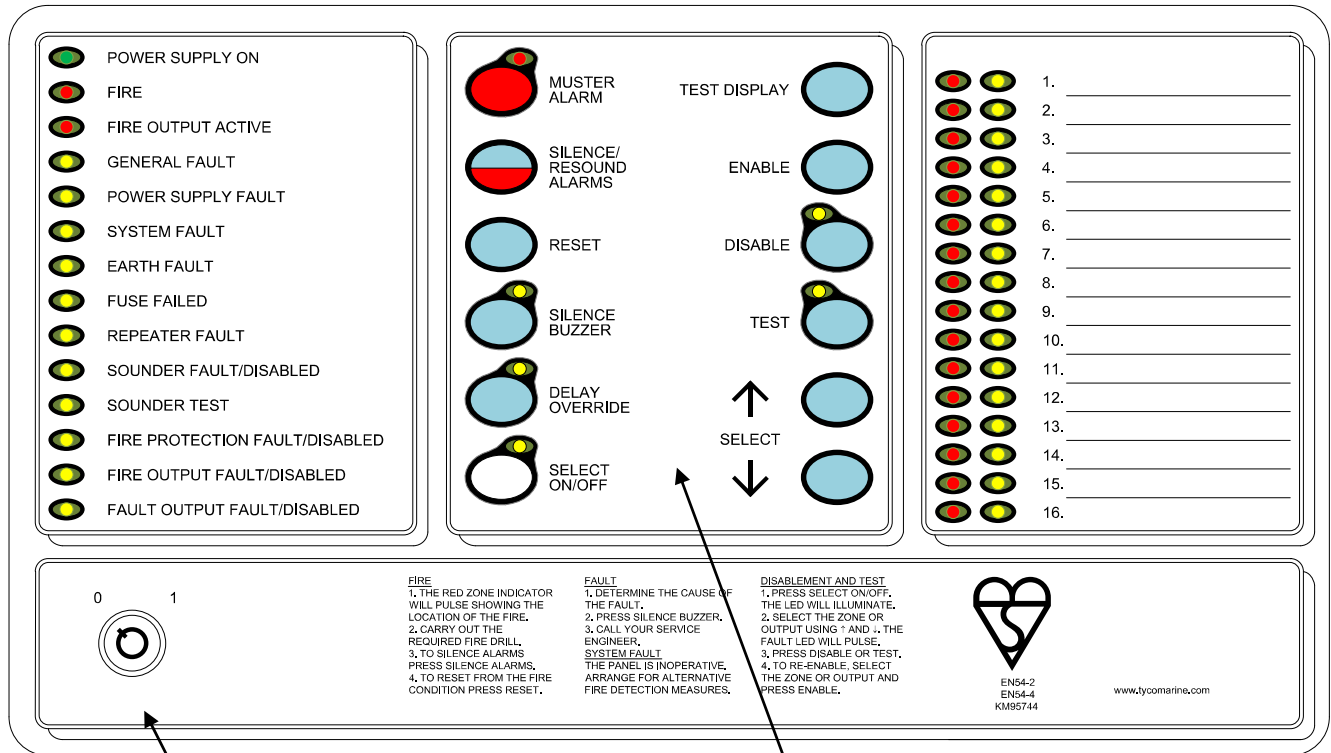

Button	Functionality	Button Availability
Manual fire alarm or Muster [Configurable option]	Manual Fire Alarm: Operates all sounders continuously and lights the Manual fire alarm LED adjacent to the button until the silence button is operated. Muster: Operate all sounders in the Muster mode.	When controls are unlocked. [May be disabled if external muster system is used]
Silence/Resound Alarms	Following a fire alarm condition, 1st operation stops sounders. The General Fire LED and the Zonal Fire LED will change from flashing to steady. 2nd operation restarts the previously silenced sounders.	When controls are unlocked.
Reset	Resets any standing fire and/or fault conditions.	When controls are unlocked and panel has fire and/or fault conditions.
Silence Buzzer	Press to stop the buzzer sounding in fire or fault conditions.	When controls are locked or unlocked.
Delay Override	Overrides the delay when delay is running, turning the delay off. All delayed outputs will operate immediately.	When the panel is in the fire condition and the delay is running.
Select On/Off	Enables the User select feature for selection of zones or outputs via Select ↑ Select ↓ for disablement/re-enablement.	When controls are unlocked.
Test Display	Press to illuminate all LEDs on the display and operate the buzzer. All indications remain active for approx 5 seconds after button press.	When controls are locked or unlocked.
Enable	Press to clear the disablement or test condition on a zone or output selected via the User Select feature.	When the flashing cursor is on a zone or output fault LED.
Disable	1] Press to disable a zone or output selected via the User Select feature. LED is lit whilst any disablement is active.	When the flashing cursor is on a zone or output fault LED.
	2] Press to view delay configuration of sounders, Fire and Fire Protection outputs.	When controls are unlocked.
Test	Press to enable One Man Test on sounders or zones as selected via the flashing cursor. LED will illuminate.	When the flashing cursor is on a zone or sounder fault LED.
Select ↑ Select ↓	Scrolls the flashing cursor through the zone and output fault LEDs on the display to select a circuit for disablement, or test. [LED illuminated when Select Mode is active]	When controls are unlocked and the Select button has been operated.
	Used to adjust the brightness of the display LEDs [Press Test Display and ↑ to increase or Test Display and ↓ to decrease]	When controls are unlocked.

T1200-C

MARINEC-P-I

1 11/12

10. PCB Layouts

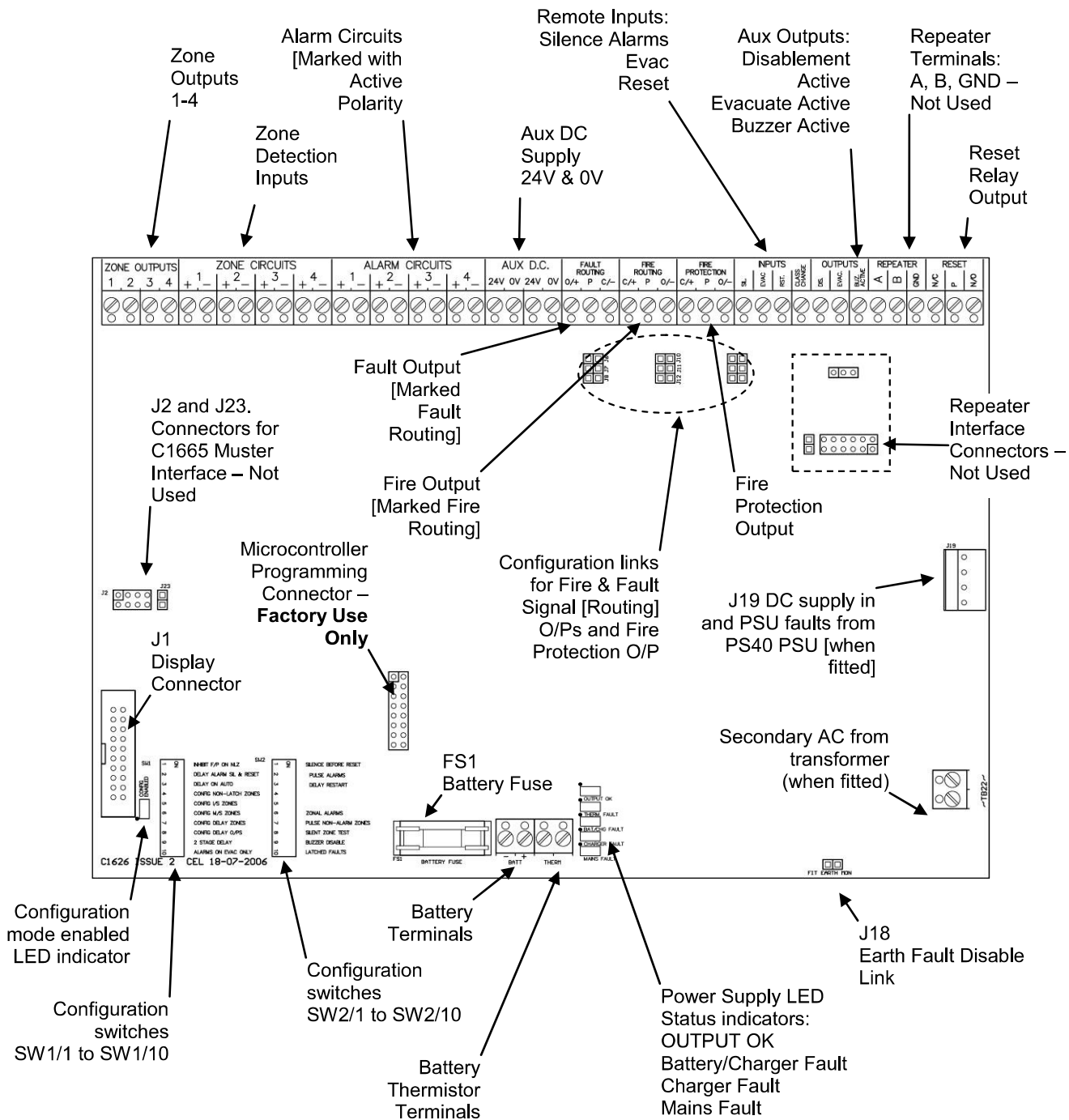

Note: "Evacuate" or "Evac" = Manual Fire Alarm/Muster

Figure 8 – C1626 PCB Layout

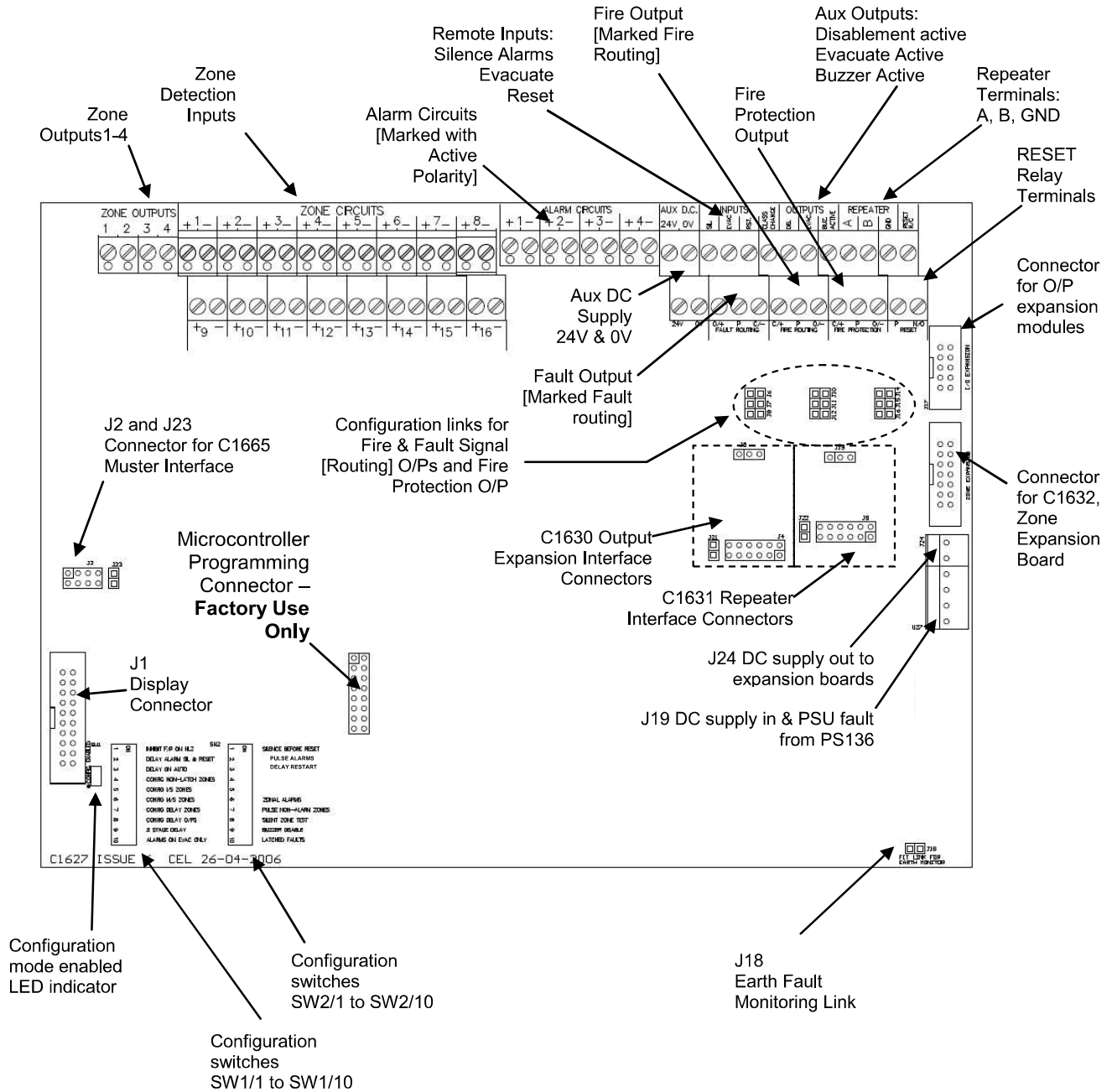

Note: "Evacuate" or "Evac" = Manual Fire Alarm/Muster

Figure 9 – C1627 Motherboard Layout

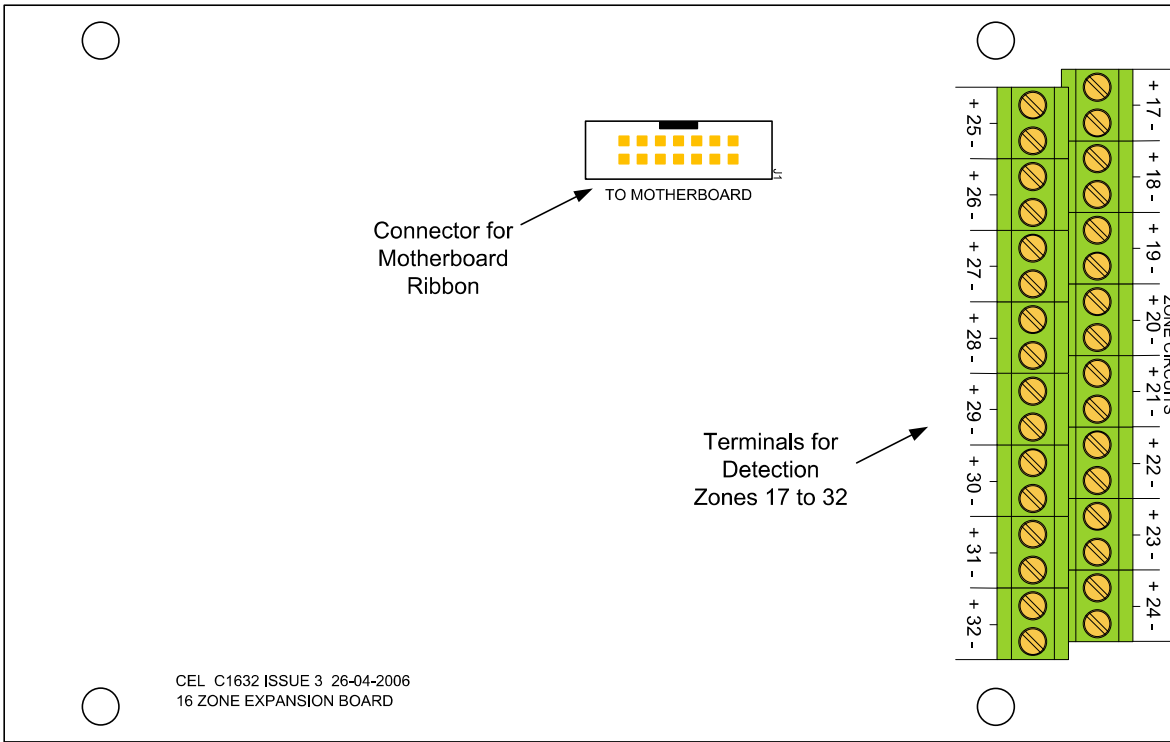

Figure 10 – C1632 16 Zone Expansion Board Layout

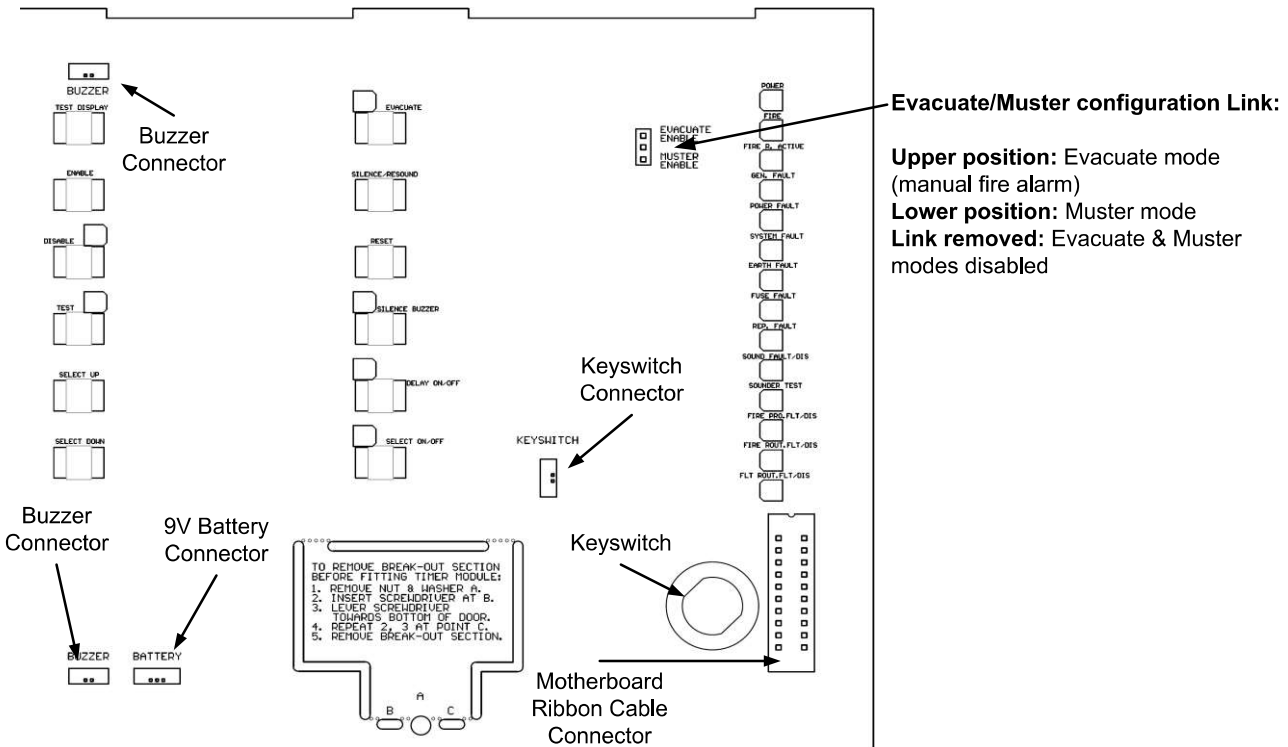

Figure 11 – Rear Right Hand Side of Display PCB

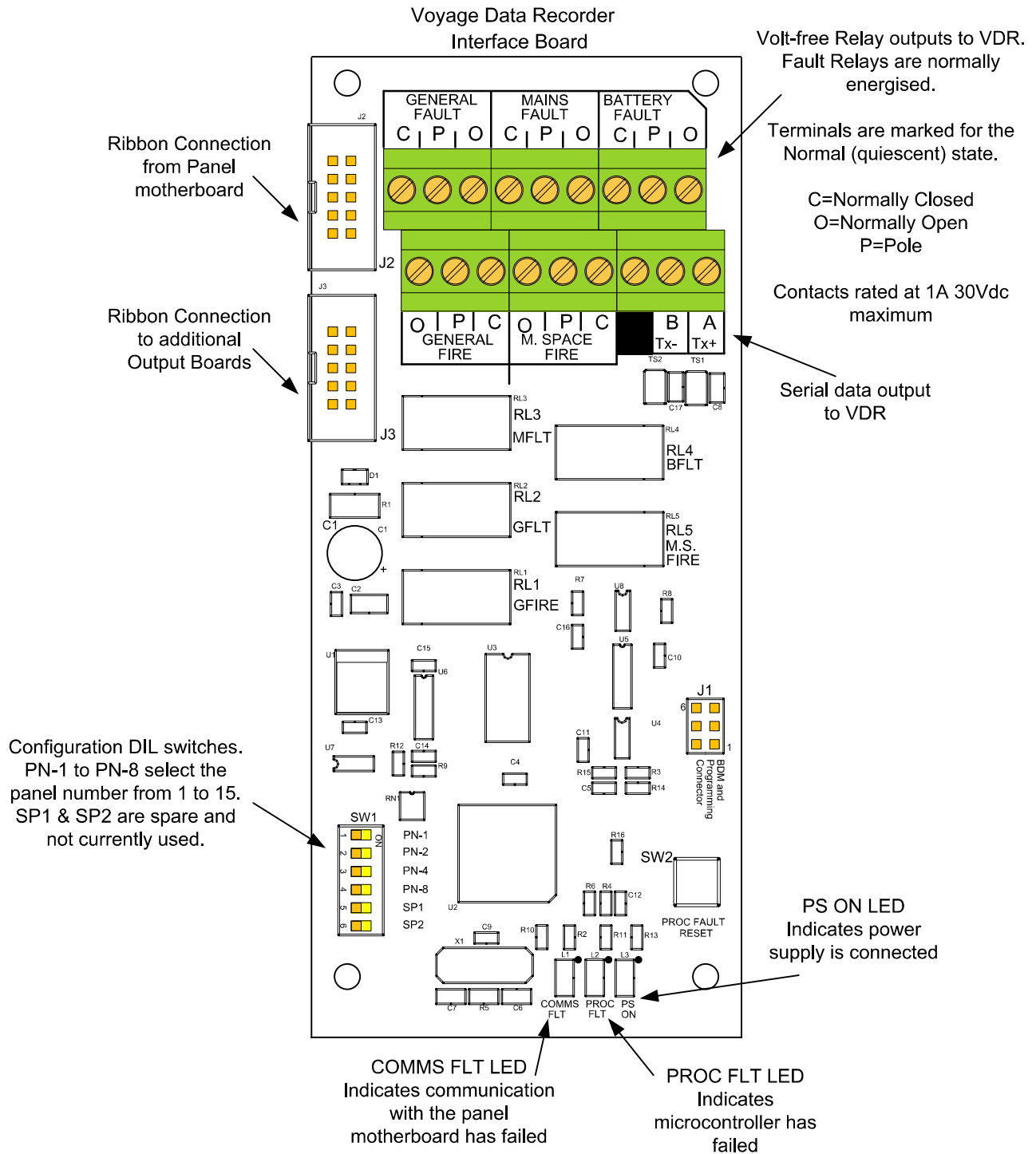

Figure 12 – C1714 VDR Output Module PCB Layout

T1200-C

MARINEC-P-I

1 11/12

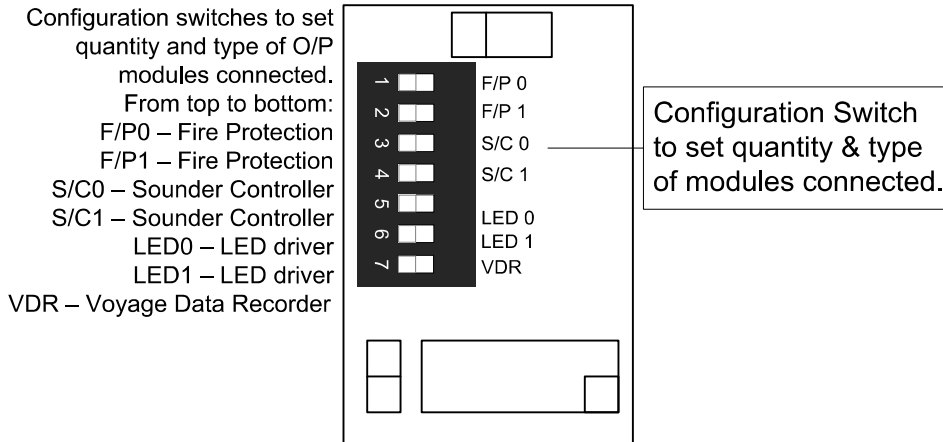

Figure 13 – C1630 Output Expansion Interface

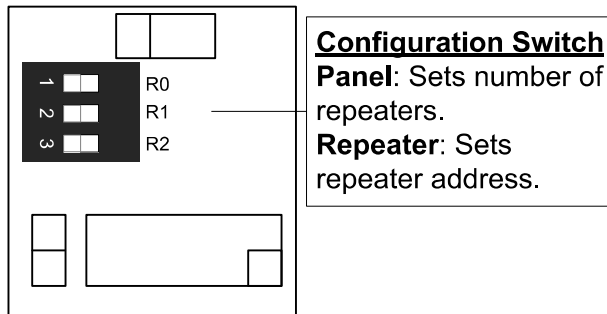

Figure 14 – C1631 Repeater Interface Board

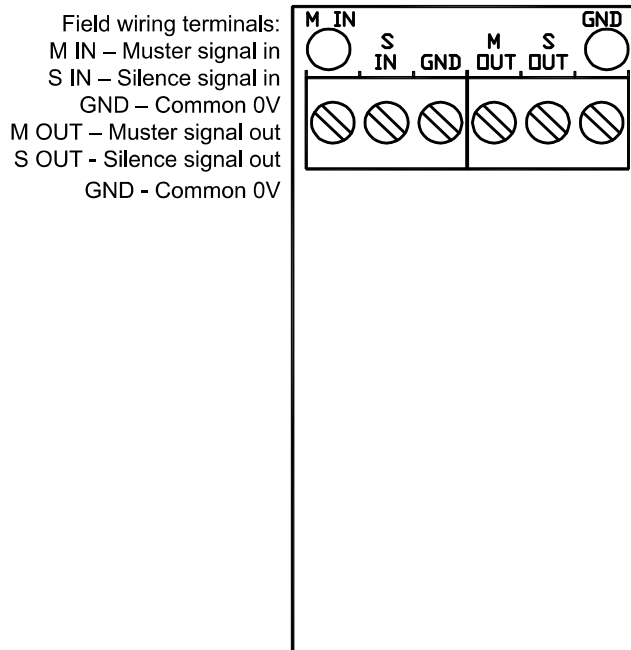

Figure 15 – C1665 Muster Interface Board